

**OPERATING PRACTICE
for the
802A
DATA LINK MONITOR**



**Part Number: 4200-0037-00
Issue: Change 2
Date: 1 November 1982**

LIST OF EFFECTIVE PAGES

Insert latest change pages and remove and dispose of superseded pages.

PAGE	ISSUE	PAGE	ISSUE
Title	Change 2	Section 4	
List of Effective Pages	Change 2	Pages 1 thru 7	Revision 1
Table of Contents	Revision 1	Section 5	
Section 1		Page 1/2	Change 2
Page 1	Revision 1	Pages 3 thru 16	Change 1
Page 2	Change 2	Pages 17 thru 41	Change 2
Pages 3 thru 8	Revision 1	Appendix A	
Section 2		Pages 1 thru 20	Revision 1
Pages 1 thru 3	Revision 1	Appendix B	
Section 3		Pages 1 and 2	Revision 1
Pages 1 thru 32	Revision 1	Appendix C	
		Pages 1 thru 5	Revision 1

ISSUE	DATE
Original	25 February 1981
Change 1	15 March 1982
Change 1	15 September 1982
Change 2	1 November 1982

802A DATA LINK MONITOR

TABLE OF CONTENTS

TITLE	SECTION	TITLE	SECTION
GENERAL DESCRIPTION	1	Monitor Function	
Introduction		Capture Mode	
Purpose of Equipment		Manual Step Mode	
Physical Description		Start/Stop Function	
Functional Description		Timeout/Stop Function	
Specifications		Elapsed Time Functions	
Options and Accessories		Elapsed Character Function	
Inspection and Warranty		Self-Tests	
INSTALLATION AND INTERCONNECTION	2	OPERATING EXERCISES	4
Service Before Use		Automatic Data Link Monitoring	
Rack Mounting		Manual Step Operations	
Interconnections		APPLICATION NOTES	5
OPERATION	3	TITLE	APPENDIX
Functional Operation		QUICK REFERENCE GUIDE	A
Operator Controls, Indicators, and Connectors		ERROR MESSAGE DESCRIPTIONS	B
Line Identification Mode		TRANSMISSION CODE DESCRIPTIONS	C

SECTION 1

1.02 Five sections and three appendixes are included in this practice. Section 1 contains general information. Instructions for installation and inter-connection of the monitor are contained in section 2. Section 3 provides operating instructions. Section 4 contains operating exercises that are provided to aid in familiarization with operation of the monitor. Application notes, which provide instructions for specific uses of the monitor, are included in section 5.

1.03 A quick reference guide of the operating procedures is included as Appendix A. Appendix B contains descriptions of the error messages associated with operation of the monitor. Descriptions of the transmission codes and a code conversion chart are included in appendix C.

1.04 Revision 1 to this manual incorporates operating changes resulting from implementation of Revision 3 software. Change 1 incorporates application notes covering the Printer/Poll/BERT Option. Change 2 incorporates an application note covering the X.25 Option.

2. PURPOSE OF EQUIPMENT

2.01 The 802A Data Link Monitor permits automatic monitoring of data on a communications data link. The DTE and DCE primary channels are monitored, and protocols, data rates, bit-per-character values, and parity are automatically detected. In synchronous protocols the transmission codes are also detected. Data rates of 50 b/s to 19.2 kb/s, may be detected. After the line configuration has been detected the parameters can be easily displayed.

2.02 When the data link configuration is known, the automatic detection process can be eliminated by manually defining the configuration. This procedure also permits introduction of triggers to start and stop logging of data, thus limiting display to selected data.

2.03 Thirty-three function-designated counters in the monitor can be programmed to record the occurrence of specific events on the data link. Two timers can also be programmed to measure the time between selected events in seconds or milliseconds.

2.04 An on-board tape recorder permits real-time recording of the data logged by the monitor for later retrieval and analysis.

3. PHYSICAL DESCRIPTION

3.01 The monitor is a self-contained, portable unit. An optional hardware kit permits rack mounting. A display section, on the left side of the front panel, consists of a 7-inch (diagonal) CRT monitor that displays traffic and configuration pages. An EIA line interface section consists of mini-banana jacks and tri-state, light-emitting diode (LED) indicators. The jacks provide access to each line for monitor or simulation purposes. The indicators display the status of each line. A multi-function keypad, located below the EIA line interface section, provides functional control of the monitor operations, hexadecimal key entries, and tape and cursor control. Access to the tape drive is adjacent to the keypad. A power switch is located in the lower right corner. The interface connectors are located on the rear panel.

4. FUNCTIONAL DESCRIPTION

4.01 The following paragraphs provide descriptions of the functional areas of the monitor. (See figure 2.)

4.02 CPU. The central processing unit (CPU), a Motorola 6800 micro-processor, is the central control for the monitor. Processing of received data is performed by the CPU, as is control of the video and the on-board tape. The 6800 operates over an eight-bit, parallel, bidirectional data bus. A 16-bit address bus provides an addressing capability of 64K bytes.

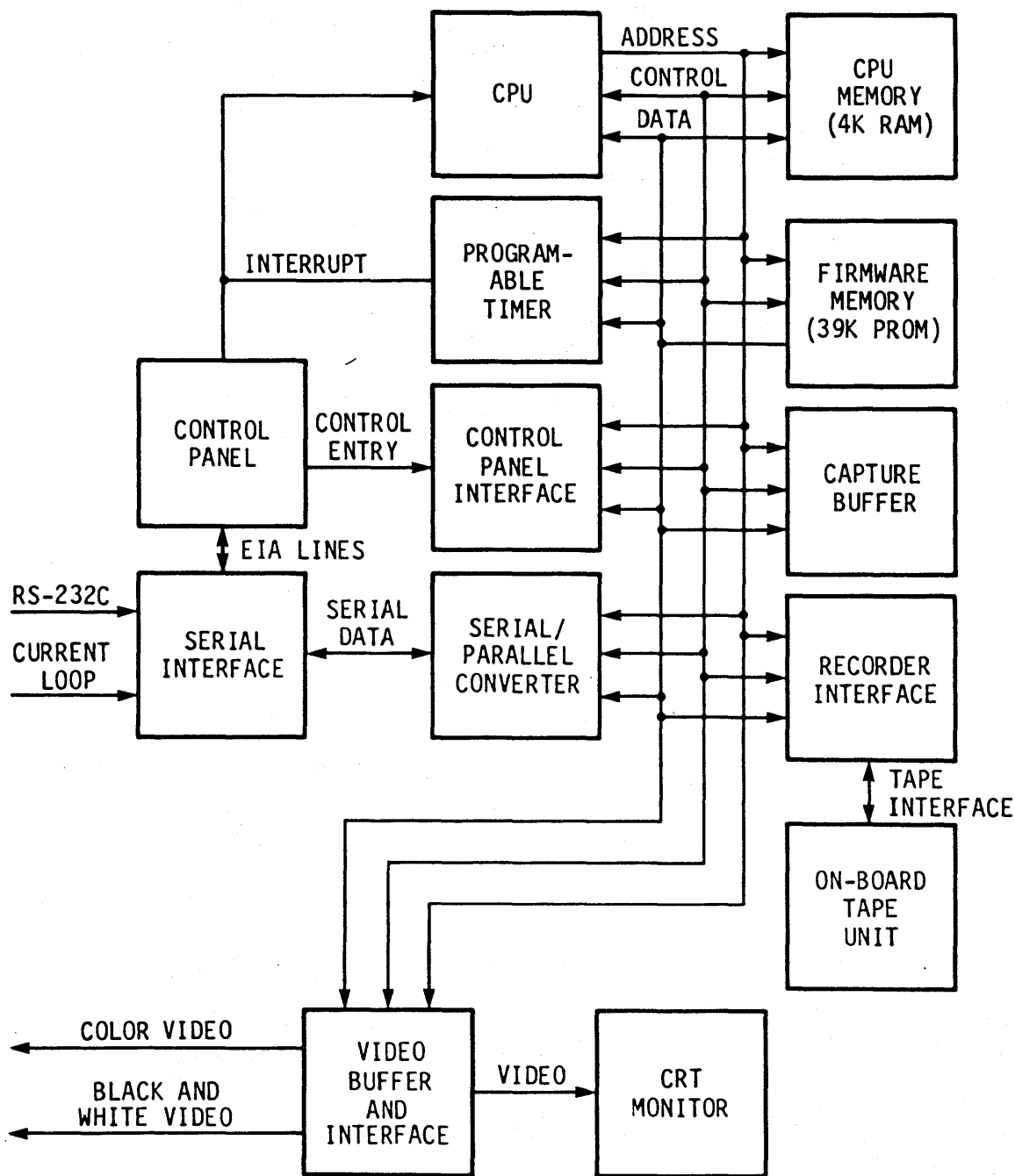

Figure 2. 802A Data Link Monitor Block Diagram

SECTION 1

4.03 CPU Memory. The CPU memory is a 4K byte static RAM that is used by the CPU for computation and temporary storage. The high speed of this memory permits the CPU to operate at its maximum capability. This memory consists of four sections. A 1K byte scratch pad is used by the CPU in execution of programs. A 1K byte execution RAM provides storage for the monitor program currently in effect. A 1K byte RAM is devoted to start/stop compilation. The start/stop conditions applicable to the program being executed are stored in this portion of memory and are called for comparison with the received data. The fourth 1K byte of this memory is used for storage of transparent text and calculation of the CRCC polynomial.

4.04 Firmware Program Memory. The firmware program memory is a 39K byte erasable programmable read-only memory (EPROM) that provides the CPU with the instructions for controlling the overall operation of the monitor.

4.05 Control Panel and Control Panel Interface. The control panel provides the manual entries for control of the monitor. Data entry to the CPU is through the control panel interface. An interrupt is provided directly to the CPU. Monitoring of the EIA lines, via the serial interface, is also provided on the control panel.

4.06 Serial Interface. The serial interface provides receipt of serial data over the RS-232 and current loop interfaces. Control of the interface is provided by the CPU. The EIA lines are provided to the control panel to permit monitoring.

4.07 Serial/Parallel Converter. The serial/parallel converter receives the input serial data stream from the serial interface, converts this stream to parallel, and, upon request, provides the parallel data to the CPU over the data bus. Control of the converter is provided by the CPU, and status is provided to the CPU.

4.08 Capture Buffer. The capture buffer is a 4K byte static RAM that receives and stores traffic from the RS-232 interface. Expansion to 8K bytes is available as an option. Half of this memory stores data while the other half stores the corresponding framing and parity error information and video attributes.

4.09 Video Buffer and Interface. The video buffer is a 2K byte static RAM. During program execution, traffic from the RS-232 interface and the corresponding video attributes are stored in the video buffer to provide real-time display of the received data. In the capture submode the entire content of the capture buffer is accessible by the video buffer. In the manual step mode the applicable configuration pages are assembled in the video buffer. The interface circuit provides the drive to the CRT monitor for display of the data in the video buffer. Color and black-and-white outputs for remote video monitors are also provided.

4.10 CRT Monitor. The CRT monitor displays the selected message stored in the video buffer. The display consists of 16 lines of 32 or 64 characters each, for a total capability of 512 or 1024 characters.

4.11 Recorder Interface. The recorder interface provides control of the on-board tape unit. This is a bidirectional interface. Parallel data received from the capture buffer is converted to serial for recording on the on-board tape unit. During playback, serial data from the tape unit is converted to parallel and routed to the capture buffer over the data bus. Control of the interface is provided by the CPU, and status is provided to the CPU.

4.12 On-Board Tape Unit. The on-board tape unit is a mini-cartridge tape recorder that provides record and playback capability for data to and from the capture buffer. The corresponding

configuration pages are recorded with the data.

4.13 Programmable Timer. The programmable timer provides timing signals for control of monitor operations.

synchronous bit-oriented (SDLC, HDLC, or similar protocols), and isochronous (async data with external clock).

5. SPECIFICATIONS

5.01 The following paragraphs list the specifications for the monitor.

5.02 Mechanical:

Height	7.0 in (17.8 cm).
Width	17.0 in (43.2 cm).
Depth	17.75 in (45.1 cm).
Weight	35 lbs (15.9 kg).

5.03 Environmental:

Temperature	0, to 50,C.
Relative Humidity	0 to 95 pct, noncondensing.

5.04 Electrical:

Input Voltage	115 or 230 V ac.
Frequency	50-60 Hz.
Power Consumption	150 VA.

5.05 Interface:

Types	RS-232-C (V.24) and current loop.
Protocols	Asynchronous, synchronous byte-controlled (BSC, IPARS, or similar protocols),

Codes

ASCII, EBCDIC, Baudot, IPARS, Selectric, EBCD, and SBT. (Custom codes available.)

Data Rates

50 kb/s to 56 kb/s full duplex.
Internal speeds; 50, 75, 100, 110, 134.5, 150, 200, 300, 600, 1200, 1800, 2400, 4800, 9600, and 19,200 b/s.
External clock; X1 and X16 b/s.

5.06 Display:

Type	CRT, 7-in diagonal.
Size	512 or 1024 characters.
Display Modes	Line multiplex (with and without pad), time multiplex, DTE only, and DCE only.
Video Attributes	Bright, normal, and dim-intensities; normal (white on black background) and reverse (black on white) characters; blinking; underline; and cursor.

SECTION 1

5.07 EIA Line Monitor:

Display	21 tri-state LEDs monitor line status; Red-Mark, Green-Space, Off-Inactive.
Test Points	21 connections to monitor EIA circuits. 1 clock input. 1 signal ground. 1 +12 V dc (spacing) output. 1 -12 V dc (marking) output. 1 programmed EIA output. 2 external inputs (transition detectors).

5.08 Memory:

CPU Memory	4K byte RAM.
Firmware Memory	39K byte PROM.
Video Buffer	2K byte RAM.
Capture Buffer	4K bytes RAM; Expandable to 12K.

5.09 Software:

Event Counters	33, up to 64K counts each.
Event Timers	2, up to 64K seconds each.
Trapping	EIA lead status and/or up to 3 patterns on each side (up to 24 characters per pattern).

Block Check Characters

BCC polynomials, CRC-16, CRC-12, CRC-6 CCITT-16, VRC/LRC, and three user specified options.

5.10 Tape Drive:

Speed	30 in/s bidirectional read/write 90 in/s bidirectional search/rewind.
Data Rate	48 kb/s.
Recording Density	1600 b/in.
Tracks	2.
Head Type	Single Gap, read/write.

5.11 Tape Cartridge:

Type	Data cartridge, 3M Scotch brand DC100A.
Size	2.4 x 3.2 x 0.5 in (6.12 x 8.10 x 1.19 cm).
Tape Length	140 ft.
Capacity	480 K bytes. (formatted).
Tape Protection	Movable tab.

5.12 Video Interface:

Sync Output	Composite, 1 V p-p into 75 ohm load, negative.
Horizontal Frequency	15.75 kHz.
Vertical Frequency	60 Hz.

Horizontal Pulse Width 3.25 us.

Vertical Pulse Width 0.5 ms.

Horizontal Scan to Retrace Ratio 76/24.

Vertical Scan to Retrace Ratio 90/10.

Color Outputs 3; Red, Green, and Blue; 1 V p-p in- to 75 ohm load.

6. OPTIONS AND ACCESSORIES

6.01 The following paragraphs describe the options and accessories that are available for the monitor. Part numbers are identified in parenthesis.

6.02 Additional 8K Byte Capture Buffer Option (802A-10).

6.03 Printer/Polling BERT Option, extends total capture buffer to 8K bytes (802A-13).

6.04 X.25 Protocol Monitoring Option, extends total capture buffer to 8K bytes (802A-11).

6.05 Custom Code Options. In addition to the standard codes provided, optional and user-defined customer codes are available. A maximum of seven codes may be included. Custom codes can be added by replacing standard codes on a one-for-one basis.

6.06 Rack Mounting Kits. Two rack mounting kits are available that permit mounting the monitor in 19- and 23-inch racks.

(a) 19-in Rack Adapter: 8220-0041-90

(b) 23-in Rack Adapter: 8220-0041-91

6.07 Padded Lightweight Field Case. A molded plastic, padded, lightweight field case (1403-0003-67) pro-

vides limited protection for the monitor during transit.

6.08 Heavy Duty Shipping Trunk. A fiberglass, heavy-duty, shipping trunk (1403-0001-00) provides protection for the monitor during shipping.

6.09 RS-232 Cable Assembly; 6 feet long, Bisex to Bisex (6010-0004-46).

6.10 Mini-Banana Patchcord Set; 10 each patchcords, 12 inches long, mini-banana to mini-banana (8220-0007-05).

6.12 Mini-Banana Patchcord Set; 10 each patchcords, 24 inches long, mini-banana to mini-banana (8220-0007-15).

7. INSPECTION AND WARRANTY

7.01 Standard Warranty. Products manufactured by Halcyon Communications, Inc., are guaranteed to be free of defects in materials and workmanship for a period of one year from the date of shipment. Halcyon will accept returned items, transportation prepaid to the nearest Service Center, for repair during the warranty period at no cost to the customer, provided that the products have not been subjected to improper installation, accident, misuse, neglect or unauthorized alterations.

7.02 Certification. Halcyon Communications, Inc., certifies that all instruments are thoroughly tested and inspected and found to meet published specifications when shipped from the factory.

7.03 Inspection. All Halcyon manufactured equipment is carefully inspected and thoroughly tested prior to shipment. Modern packaging techniques are used to prevent damage in shipment.

7.04 If goods are received in a damaged condition, A CLAIM SHOULD BE FILED WITH THE CARRIER IMMEDIATELY. Normally, the carrier will want to inspect the shipping carton and packing materials.

SECTION 1

A copy of this claim should be forwarded to Halcyon.

7.05 If equipment which has no apparent damage does not operate properly when tested in accordance with the instructions, it should be returned to one of the addresses shown for repair or replacement. Unauthorized field repairs or modifications may invalidate the warranty.

7.06 Repair Service. When returning equipment for repair, utmost care in packing should be taken to avoid shipping damage. If available, use the original cartons and packing material. Shipping charges should be prepaid.

7.07 Returned equipment which is covered by the warranty will be repaired as expeditiously as possible and shipped prepaid.

7.08 If the equipment is not covered by warranty, a quotation for repair charges will be made first. Repairs will be made after authorization (purchase order) to proceed is received.

7.09 Service Centers. Halcyon Service Centers are located at the listed addresses. Instruments should be returned to Halcyon, Inc., Customer Service, at the nearest location.

DOMESTIC

2001 Gateway Place
Suite 201 East
San Jose, CA 95110
(408) 298-2065
TWX-910-338-0562

19782 McArthur Blvd.
Suite 210
Irvine, CA 92715
(714) 815-1057

255 Old New Brunswick Road
North Tower, 3rd Floor
Piscataway, NJ 08854
(201) 981-0650

1931 J. Rohlwing Road
Rolling Meadows, IL 60008
(312) 255-3000

8375 Dunwoody Place
Building 3
Atlanta, GA 30338
(404) 998-2210

1000 Main Street
Suite 180
Grapevine, TX 76501
(817) 481-7548

1600 Pennsylvania Ave.
Wilmington, DE 19806
(302) 654-2611

DIVISION HEADQUARTERS

#1 Halcyon Plaza
2121 Zanker Road
San Jose, CA 95131
(408) 293-9970

802A DATA LINK MONITOR

SECTION 2

INSTALLATION AND INTERCONNECTION

CONTENTS	PAGE
1. GENERAL	1
2. SERVICE BEFORE USE	1
3. RACK MOUNTING	1
4. INTERCONNECTIONS	1
A. Data Interface	1
B. Current Loop	1
C. Black and White Video Monitor Interface	2
D. Color Video Monitor Interface	2

Figures

1. Data Interface Interconnections .	2
2. Current Loop Pin Assignments	3

1. GENERAL

1.01 Contained in this section are instructions for installation and interconnection of the 802A Data Link Monitor. Included are instructions for servicing, rack mounting, and interconnecting the monitor.

2. SERVICE BEFORE USE

2.01 The analyzer can operate from a line voltage of either 115 or 230 V ac. Each voltage is plus or minus 10 per cent. Ensure that the proper voltage source is available before connecting to the power line.

3. RACK MOUNTING

3.01 The analyzer can be mounted in a 19-inch or 23-inch rack using the optional rack adaptors. To install the rack adaptors proceed as follows:

(a) Remove the two (2) screws that secure each rubber bumper to the sides and bottom of the assembly and remove the rubber bumpers.

(b) Attach an L bracket to each side of the front panel assembly using the screws provided.

4. INTERCONNECTIONS

4.01 The following paragraphs provide instructions for connecting the monitor using data and current loop interfaces. Instructions for connecting remote black-and-white and color video monitors are also provided.

A. Data Interface

4.02 The DATA INTERFACE connector on the rear of the monitor provides an RS-232 interface for connection to either terminal or modem equipment. (See figure 1.)

B. Current Loop

4.03 The current loop circuits consist of a receiver and 60, 40, and 20 mA current sources for both the DTE and DCE inputs. The connections to the CURRENT LOOPS connector on the rear panel are shown in figure 2.

SECTION 2

C. Black and White Video Monitor Interface

4.04 A composite video output is available on the rear panel of the monitor to provide the video display on a remote black-and-white video monitor. Connect the video monitor input to the B & W connector.

D. Color Video Monitor Interface

4.05 Outputs are available on the rear panel of the monitor to provide the video display in color on a remote color video monitor. Connect the color monitor sync input to the SYN connector and the video inputs to the RED, GRN, and BLU connectors.

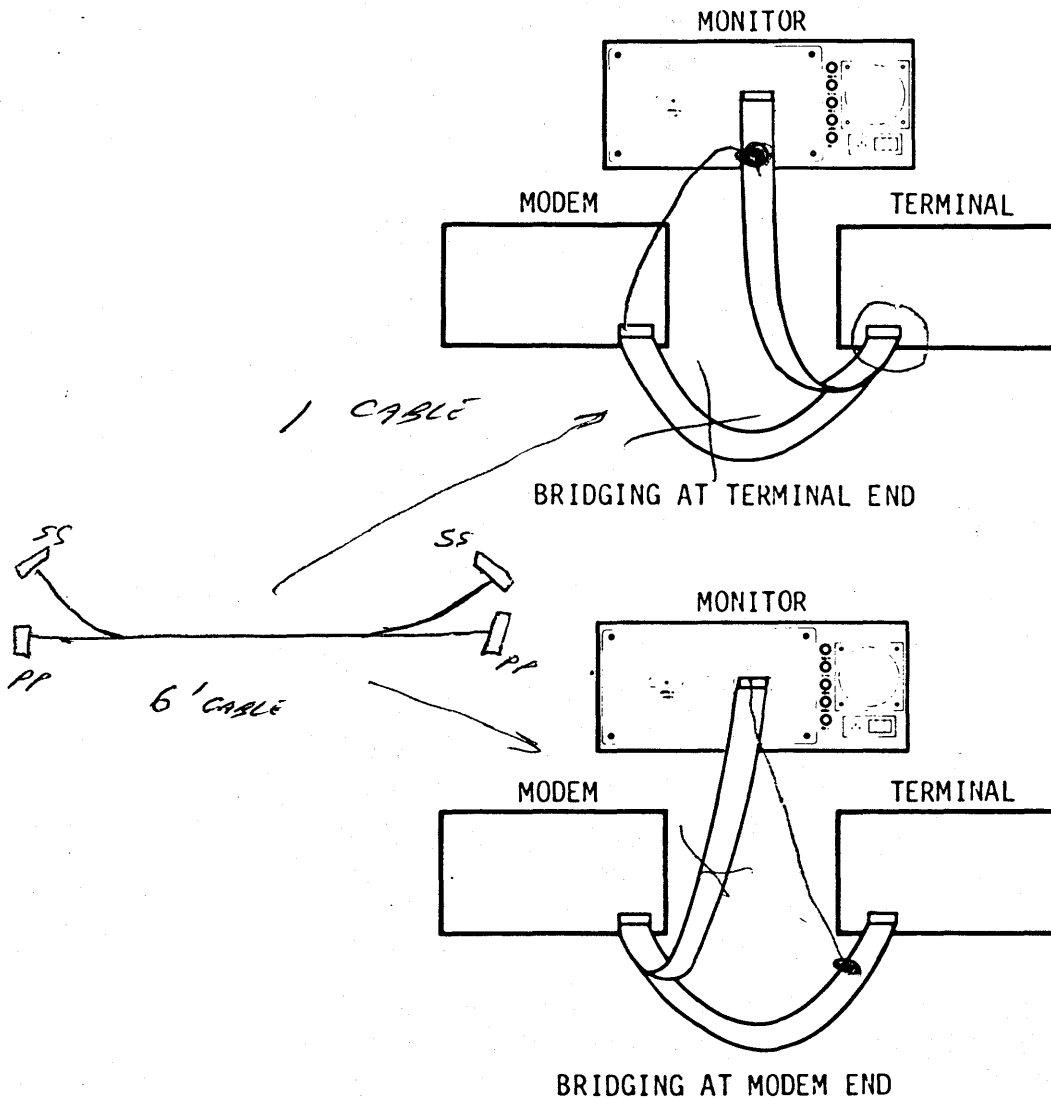

Figure 1. Data Interface Interconnections

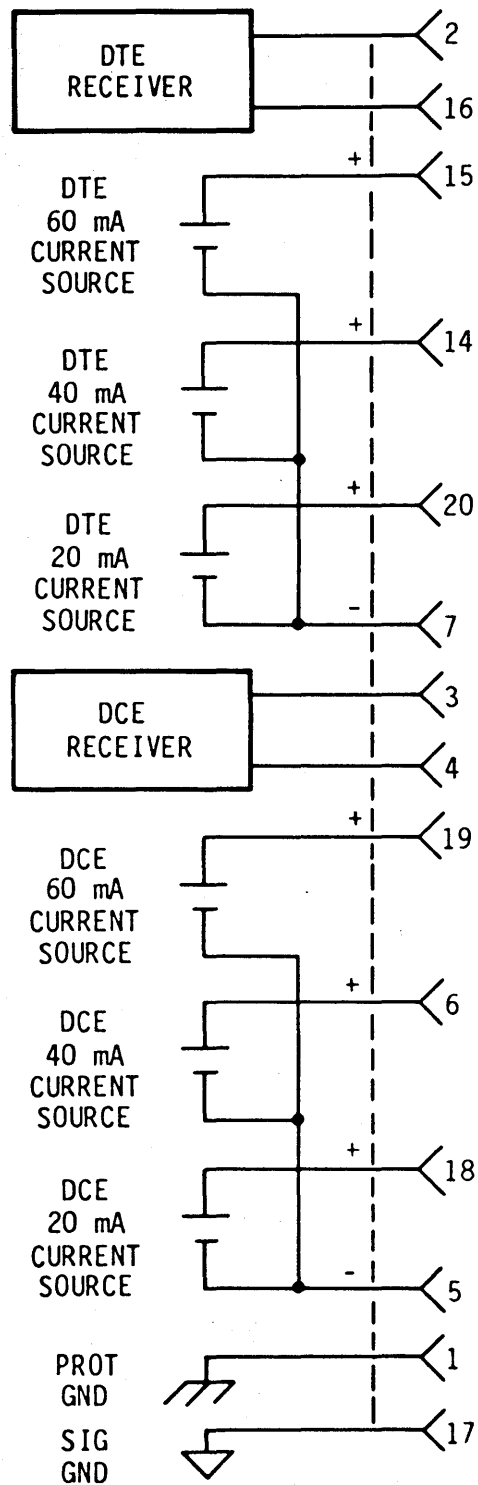

Figure 2. Current Loop Pin Assignments

802A DATA LINK MONITOR

SECTION 3

OPERATION

<ul style="list-style-type: none"> 1. GENERAL 2 2. FUNCTIONAL OPERATION 2 <ul style="list-style-type: none"> A. Line Identification Mode 2 B. Line Configuration Parameters 2 C. Monitor Configuration Parameters 3 D. Display Configuration Parameters 4 E. Run Mode 4 F. Monitor Function 4 G. Start/Stop Function 5 H. Timeout-Stop Function 5 I. Elapsed Time Functions 6 J. Elapsed Character Function .. 6 K. Capture Mode 6 L. Tape Operation..... 6 3. OPERATOR CONTROLS, INDICATORS, AND CONNECTORS 7 <ul style="list-style-type: none"> A. EIA Line Interface Section 8 B. Function Keys 8 C. Hexadecimal Keys 9 D. Tape Keys 9 E. Cursor Keys10 F. Power Switch10 G. Rear Panel10 	<ul style="list-style-type: none"> 4. AUTOMONITOR TM MODE10 5. MONITOR FUNCTION11 6. CAPTURE MODE12 7. MANUAL STEP MODE13 <ul style="list-style-type: none"> A. Line Configuration Parameters13 B. Monitor Configuration Parameters16 C. Display Configuration Parameters23 8. START/STOP FUNCTION24 9. TIMEOUT-STOP FUNCTION26 10. ELAPSED TIME FUNCTIONS26 11. ELAPSED CHARACTER FUNCTION26 12. TAPE OPERATION27 13. SELF-TESTS31 Figures <ul style="list-style-type: none"> 1. Monitor Front and Rear Views 7 2. Line/Display Configuration Page14 3. Async-BCP Start/Stop Configuration Page.....19 4. BOP Start/Stop Configuration Page20 5. Counter Configuration Page25 6. Tape Configuration Page28 7. 802 Self-Test Menu32
---	--

SECTION 3

1. GENERAL

1.01 This section contains the instructions for operation of the 802A Data Link Monitor. Included are discussions of the functional operation, descriptions of the operator controls, indicators, and connectors, and the operating procedures.

2. FUNCTIONAL OPERATION

2.01 The monitor is designed to perform automatic line monitoring. Operation commences in the line identification mode. From the line identification mode the monitor automatically enters the monitor function of the run mode, if line detection takes place, or the manual step mode can be entered manually. The manual step mode permits manual selection of line configuration, monitor configuration, and display configuration parameters. The default function of the monitor is the monitor function, which is entered following automatic line detection. Other functions, which can be selected in the manual step mode, include start-stop, timeout-stop, elapsed time, elapsed character, and real-time tape. These operations are further described in the following paragraphs.

A. Line Identification Mode

2.02 The line identification mode is entered automatically following turn-on. In this mode the DTE and DCE sides of the line are individually monitored, and the monitor searches to identify the protocol, bit rate, transmission code and other line configuration parameters for each side. When the line configuration parameters are detected for one side of the line, operation automatically enters the monitor function of the run mode. The default monitor and display configuration parameters are in affect at this time. Manual selection of these parameters can be performed in the manual step mode.

B. Line Configuration Parameters

2.03 The line configuration parameters include those parameters associ-

ated with the received data. Manual selection of these parameters is performed in the manual step mode. These parameters include protocol, bit rate, transmission code and number of bits, parity, CRCC polynomial, sync characters, resync characters, data channel assignment, data sense, data bit order, and data encoding.

2.04 Protocol. Three standard protocols are provided with the monitor. These are asynchronous, synchronous, SDLC, and HDLC-1. Additional protocols are optional.

2.05 Bit Rate. Eighteen bit-rate selections are provided in the manual step mode. These selections are as follows:

50, 75, 100, 110, 134.5, 150, 200, 300, 600, 1200, 1800, 2400, 4800, 9600, and 19,200 b/s and external times 1 (EXT X1), external times 16 (EXT X16), FROM DCE, and FROM DTE.

2.06 The default condition is FROM DCE for bisync, SDLC, and HDLC-1, and 1200 for ASYNC.

2.07 Transmission Code. Seven transmission codes are provided as standard with the monitor. These codes are ASCII, EBCDIC, Baudot, Selectric, EBCD-2740, IPARS, and SBT. The default code is EBCDIC. Other codes may be included as options. Different selections can be made for each side of the line.

2.08 Bit Per Character. Default bit per character values are provided for each transmission code. The values are five bits for Baudot, six for SBT and IPARS, seven for ASCII, Selectric, and EBCD, and eight for EBCDIC. Separate selections are provided, and any value from five to eight bits may be selected. Different values can be selected for each side of the line.

2.09 Parity. Parity selections are provided for asynchronous and bi-

sync protocols. These selections are none, odd, and even. The default condition is none. Different selections can be made for each side of the line.

2.10 CRC Polynomial. Four different cyclic redundancy check character polynomial selections are provided. The selections are CRC-16, CCITT-16, CRC-12, CRC-6, and VRC/LRC. The default conditions are CRC-16 for bisync, and CCITT-16 for SDLC and HDLC-1. These selections are only applicable with synchronous protocols. Separate selections can be made for each side of the line.

2.11 Sync Characters. Selection of one or two sync characters for use in synchronous protocols is provided. The default characters in hexadecimal are 16 and 16 for bisync ASCII, 32 and 32 for bisync EBCDIC, 3F and 3E for IPARS, 3A and 3A for transcode, and 7E for bit-oriented protocols; however, any characters can be manually selected. Different characters can be entered for each side of the line.

2.12 Resync Characters. Selection of one or two resync characters for use in synchronous protocols is provided. The default characters are the maximum bits for each code: 1F for five-bit codes, 3F for six bit, 7F for seven bit and FF for eight bit (except 7E for bit-oriented protocols and 00 for IPARS). Any characters can be manually selected, however. Different characters can be entered for each side of the line.

2.13 Data Channel. Data channel selections permit monitoring of the primary or secondary channels or of the current loop interface. Separate selections can be made for each side of the line.

2.14 Data Sense. Selections of normal and inverted data sense are provided for each side of the line. The default condition is normal.

2.15 Data Bit Order. Selections of normal and reverse data bit order are provided for each side of the line. The default condition is normal.

2.16 Data Encoding. Selections of direct and non-return-to-zero-inverting (NRZI) data encoding are provided. The default condition is direct.

C. Monitor Configuration Parameters

2.17 The monitor configuration parameters include those parameters associated with the action performed by the monitor in monitoring the received data. Selection of the monitor configuration parameters is performed in the manual step mode. These parameters include monitor, mark external EIA input, suppress text, suppress characters, start/stop function, and start/stop triggers.

2.18 Monitor. The monitor parameter selections permit monitor and display of data from the DTE, DCE, or both the DTE and DCE sides of the line. The default condition is DTE and DCE.

2.19 Mark External EIA Input. This parameter permits monitoring of a selected EIA lead and marking of the displayed data upon the occurrence of a positive transition, negative transition, marking, or spacing condition. The default condition is none.

2.20 Suppress Text. This parameter permits suppressing storage and display of text from the received data. Separate selections can be made for each side of the line. The default condition is none.

2.21 Suppress Characters. This parameter permits suppressing storage and display of two characters from the received data. Separate selections can be made for each side of the line. The default condition is no character suppression.

SECTION 3

2.22 Pattern Match. This permits selection of a one or two-character pattern to be used in monitoring the received data. The occurrence of the pattern in the displayed data will be indicated by a flashing underline. These occurrences will also be counted. Separate selections can be made for each side of the line. The default condition is no pattern match.

2.23 Start/Stop Function. This parameter permits selection of the type of start/stop function to be performed by the monitor. Monitor, timeout-stop, elapsed time, and elapsed character functions are provided. The default condition is monitor. These functions are further described in paragraphs 2.32 through 2.40.

2.24 Start/Stop Triggers. These parameters permit selection of external EIA inputs or data strings for use as start and stop triggers. The occurrence of a BCC or FCS error or a timeout value of up to 9,999 seconds or continuous operation can also be selected as a stop trigger. A combined post-trigger count of 9,999 characters from the DTE and DCE sides of the line can be selected for storage and display following the occurrence of a stop trigger. The trigger count parameter permits operation of the start/stop sequence continuously or any number up to 9,999 times. An alarm can be programmed to sound upon the occurrence of a stop trigger.

D. Display Configuration Parameters

2.25 Two display configuration parameters, associated with the display of the received data, are also selected in the manual step mode. These parameters include display mode and display size.

2.26 Display Mode. This parameter permits selection of the way the received data is displayed on the screen. In the line multiplex mode the received data from the DTE and DCE side of the line are displayed on alternate lines on

the screen with the DTE data starting on the third line and the DCE data on the fourth. Pad characters are suppressed. The line multiplex-pad mode is the same as the line multiplex mode except the pad characters are stored and displayed. In the time multiplex mode the DTE and DCE data are displayed on the screen alternately on the same lines in the sequence the data is received. The display DTE and display DCE modes permit continuous display of the data from the selected side of the line only. Data from both sides of the line are still logged into the capture buffer and can be selected for display in the capture mode. The fast mode permits monitoring at bit rates up to 56 kilobits per second. Data is logged into the capture buffer but not displayed in real time. Start/stop, suppress text and character, and counter operations are not operable in this mode. The default mode is line multiplex-pad.

2.27 Display Size. This parameter permits selection of the size of the data display. Selections include 512 characters consisting of 16 lines of 32 characters each and 1024 characters consisting of 16 lines of 64 characters each.

E. Run Mode

2.28 The type of operation performed by the monitor in the run mode is determined by the start/stop function selected. The functions include monitor, start/stop, timeout-stop, elapsed time, and elapsed character.

F. Monitor Function

2.29 In the monitor function of the run mode, traffic from the interface is logged into the capture buffer and displayed on the screen in real time. The first two lines on the screen provide an abbreviated display of the line configuration parameters. The top line displays the parameters for the DTE side of the line in normal video (white characters on black background). The DCE parameters are displayed on the

second line in reverse video (black characters on white background). Each line displays the detected protocol, transmission code and number of bits, sync characters (bisync only), parity, and clock source or bit rate.

2.30 The received traffic is displayed on the remainder of the screen as it is received: the DTE data in normal video and the DCE data in reverse video. In the default display mode, line multiplex-pad, the DTE data is displayed from left to right starting on the third line of the screen and on alternate lines to the bottom of the screen. The DCE data is displayed in a similar manner starting on the fourth line. Pad characters are displayed.

2.31 Several operations are available in the monitor function including freeze, code/hex display, capture, transparent sync, resync, turnaround time, mark, and transmission code selection.

G. Start/Stop Function

2.32 In the start/stop function of the run mode, start and stop triggers can be entered that initiate and stop logging and display of traffic. Start trigger selections include transitions on a selected EIA line and/or up to six selected data strings: three for each side of the line. The data strings for each side of the line can be programmed to operate in either an AND or OR configuration, and the two sides of the line can be programmed to operate in either an OR or an independent configuration. Using the independent configuration the two sides of the line can be monitored independent of each other. The EIA trigger, if active, is always in an OR configuration with the start strings.

2.33 In addition to transitions on a separately selected EIA line and separately selected stop strings, stop triggers can include a timeout value and

the occurrence of an error. These parameters are always in an OR configuration with the EIA trigger and the stop strings. In bit-oriented protocols the occurrence of a flag can also be selected as the stop trigger in lieu of the stop strings.

2.34 Six separate data strings can also be entered for use as stop triggers: three for each side of the line. The timeout value can be entered as any value up to 9,999 seconds. The time is measured from the occurrence of the start trigger.

2.35 In this function the received traffic is displayed, in accordance with the other monitor and display configuration parameters, starting with the start trigger and ending with the stop trigger. Following the stop trigger, operation enters the capture mode.

2.36 The start/stop sequence can be performed continuously or any number up to 9,999 times, by entering a trigger count value. Operation continues in the run mode until the sequence has been repeated the selected number of times; then operation enters the capture mode.

2.37 A post-trigger count value can be entered to permit logging and display of a total of up to 9,999 characters, from both sides of the line, following the occurrence of the stop trigger. This value can exceed the capacity of the capture buffer; so care should be exercised to avoid overflow and loss of the trigger data.

H. Timeout-Stop Function

2.38 The timeout-stop function is similar to the start/stop function. The only difference is that the trigger count value is in an OR configuration with the timeout value. If the timeout is completed before the trigger count, operation stops.

SECTION 3

I. Elapsed Time Functions

2.39 The elapsed time functions use the start/stop triggers, as described for the start/stop function, to measure the time between the occurrence of two events. In this case traffic from the interface is not logged into the capture buffer, or displayed on the screen. The time, in either seconds or milliseconds, is logged and displayed instead. The calculated time for each measurement is displayed repeatedly on the screen, one line at a time, from left to right and from top to bottom. Display of the values continues until the capture buffer is full. At this time operation automatically enters the capture mode. The capture mode can also be entered manually at anytime during operation.

J. Elapsed Character Function

2.40 The elapsed character function is similar to the elapsed time functions, except the number of characters between the start and stop triggers are counted and displayed. The characters count continues until the capture buffer is full, and the capture mode is entered.

K. Capture Mode

2.41 The capture mode is subordinate to the run mode. In this mode logging of data into the capture buffer is stopped, and the captured data is displayed with the earliest received 14 lines of data displayed first. Scrolling permits display of the remaining data. The type of data displayed depends on the function being performed in the run mode. For the traffic type functions--monitor, start/stop, and timeout-stop--the received traffic is displayed. For elapsed time and elapsed character functions the elapsed time or character counts are displayed.

2.42 Several operations are available in the capture mode including code/hex display, manual step selection, cursor positioning, bit shifting, and event counting.

L. Tape Operation

2.43 The on-board tape recorder provides an extended capture buffer capability for real-time recording and later playback of the data monitored in the run mode. Six functions are performed by the recorder; format, verify, record, 1 (manual), record 2 (automatic) directory display, and replay.

2.44 Format. Before data can be recorded on a tape, the tape must be formatted. Formatting consists of recording headers periodically on both tracks of the tape. Once the tape has been formatted the tape can be used in the record function.

2.45 Verify. The format of a previously recorded or formatted tape can be checked by the verify function. Any errors are identified.

2.46 Record. In the record functions, data from the line is logged into the capture buffer in accordance with the line and monitor configuration parameters. When a two kilobyte block of data has been logged, that block is recorded on the tape as one record while data continues to be logged into the other half of the capture buffer. Recording continues in two kilobyte blocks until the run mode is terminated.

2.47 Two record functions are provided. In the manual function, recording is initiated by pressing CAPTURE. In the automatic function, recording is initiated by pressing RUN and terminated as the result of a stop trigger, the end of track or end of tape is reached, or by pressing CAPTURE.

2.48 End of track and end of tape are record mode selections that limit recording to the one or two tracks. A third selection, continuous, allows continuous recording alternately on the two tracks. After the recording on track two is completed, recording resumes on track one. Previously recorded data is destroyed.

2.49 Directory Display. The directory display function permits reading a prerecorded tape and listing each file by file number and indicating the name, type of data, track, and length. The file number and name are entered by the operator before recording takes place. The type of data is either traffic, identified by a 1, or configuration, identified by a 2. Track indicates the file is recorded on track 1 or 2. The length indicates the length of the file in blocks.

2.50 Replay. In the replay function any file can be selected and read from tape and displayed on the monitor. The tape file acts as an extended

capture buffer with a capacity of up to 480 kilobytes. The entire file can be displayed by scrolling the displayed data.

3. OPERATOR CONTROLS, INDICATORS, AND CONNECTORS

3.01 This part contains descriptions of the controls, indicators, and connectors of the monitor. (See figure 1.) For purposes of this discussion the monitor is divided into six functional sections: the EIA line interface section, the tape function keys, the cursor function keys, the function key pad, the hexadecimal key pad, and the rear panel.

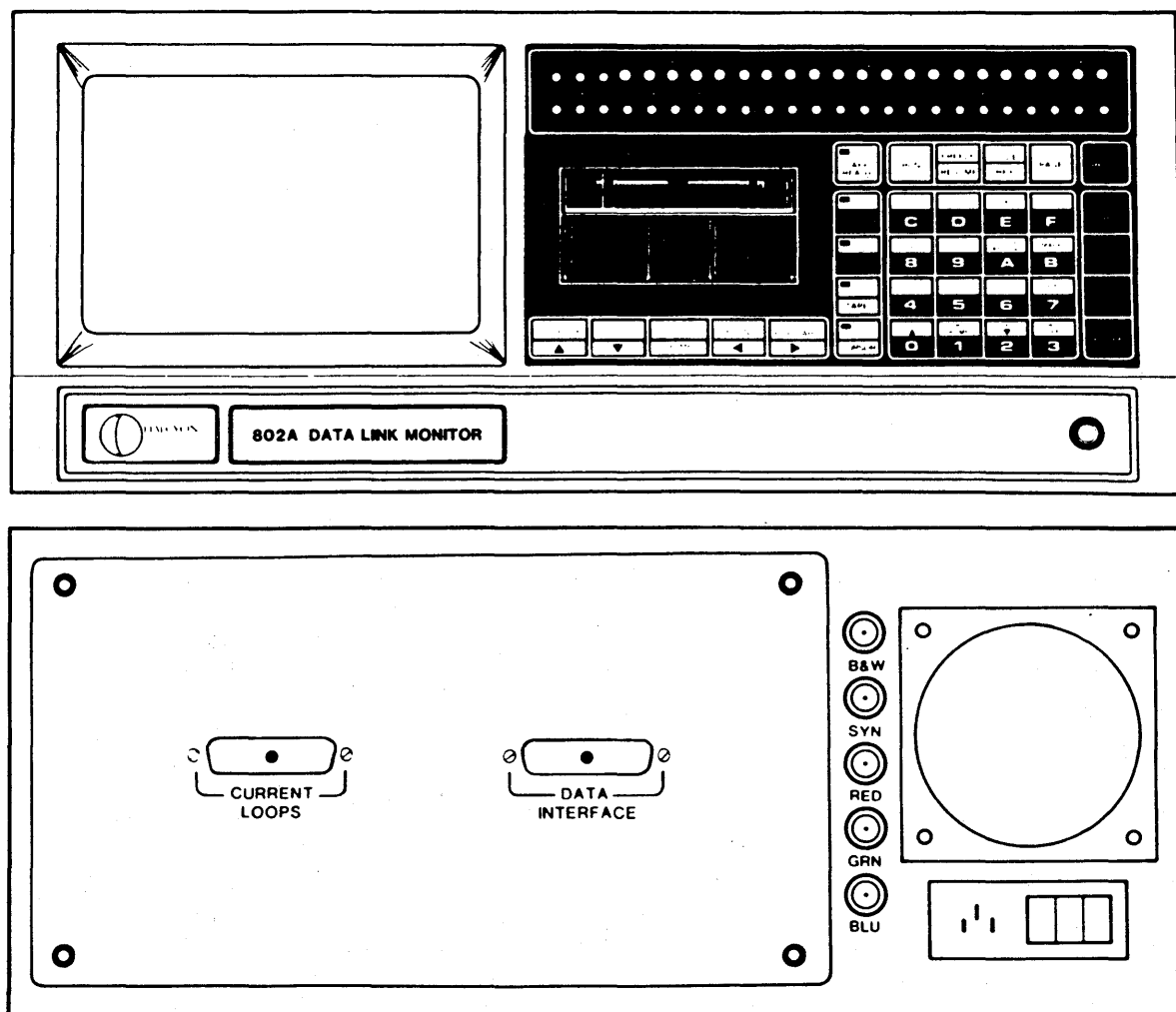

Figure 1. Monitor Front and Rear Views

SECTION 3

A. EIA Line Interface Section

3.02 CLK: Mini-banana jack; permits input of external clock for test use. Also can be used to input a selected EIA line for use in the start/stop function.

3.03 GND: Mini-banana jack; provides ground connection for test use.

3.04 EIA +V: Mini-banana jack; provides a +12 V dc output for use in simulating a spacing (binary 0) condition on an EIA line.

3.05 EIA -V: Mini-banana jack; provides a -12 V dc output for use in simulating a marking (binary 0) condition on an EIA line.

3.06 EXT OUT: Mini-banana jack; provides an output for test purposes, in response to programmed conditions.

3.07 EXT IN: Mini-banana jack; permits input of any selected EIA line for use in marking or start/stop functions.

3.08 2 thru 25: Tri-state LEDs and mini-banana jacks; indicate status of and provide test points for direct access to 21 EIA interface lines. LEDs indicate red for marking (off) condition, green for spacing (on) condition, or off for inactive condition of the line. The first row of numbers (2 thru 25) identifies the RS-232 connector pin numbers. The second row indicates the CCITT equivalent circuit numbers. The third row provides abbreviated circuit descriptions.

B. Function Keys

3.09 TAPE READY: Indicator lit when tape cartridge is inserted in tape drive.

3.10 RUN: Initiates execution of the selected configuration in monitoring the data link. Resumes execution from the capture mode.

3.11 FREEZE/RESUME: Alternately stops and resumes display of traffic in the run mode. Does not affect accumulation of data in the capture buffer.

3.12 CODE/HEX: Alternately selects display of data as characters or hexadecimal equivalents.

3.13 PAGE: Initiates display of line/display configuration page and steps through successive pages. After all pages have been displayed, wraps around to the capture display and repeats.

3.14 RESET: Returns operation to the Automonitor mode. Any existing configurations are cleared.

3.15 FUNCTN: Selects function operation of the associated key switches. When the indicator is lit the function (white on gray) switch legends are in effect.

3.16 CAPTURE: Stops program execution in the run mode and stops accumulation of data in the capture buffer.

3.17 SEND: Not operable at this time.

3.18 DEFAULT: Operable in the manual step mode to select the default conditions for all the parameters on the displayed configuration page.

3.19 SHIFT: Operable in the capture mode. Pressing SHIFT followed by SCROLL initiates automatic scrolling.

3.20 DON'T CARE: Provides a nondefinitive entry for string character, or bit parameters on the configuration pages. Identified in video by a dim X in reverse video. Also operable in the run mode to alternately disable and enable the start/stop function.

3.21 HEX PAD: Selects hexadecimal operation of the associated key

switches. When indicator is lit the hexadecimal switch legends are in effect.

3.22 TRANSP SYNC: Forces logging and display of data without detection of sync in bisync protocol.

3.23 RESYNC: Forces operation into sync hunt mode in synchronous protocols. Not operable when transparent sync has been selected.

3.24 TURN AROUND: Selects time-multiplexed display mode. Alternately initiates and disables display of turnaround time. Turnaround time is measured from the trailing pad character on one side of the line to the first sync character in the response.

3.25 MARK: Alternately initiates and disables an underline marking of all data logged into the capture buffer and displayed on the screen.

3.26 STEP: In multiple choice entries, with the cursor in the reverse video field, permits stepping through multiple choice entries. Also operable in the capture mode to initiate entry of a step scroll value.

3.27 TAPE: Selects the tape operation of the tape/cursor key switches. When indicator is lit the tape (upper) legends are in effect.

3.28 EVENT COUNT: Not operable at this time.

3.29 COPY: Not operable at this time.

3.30 PRINT: Not operable at this time.

3.31 CLEAR: Operable in manual entry of character strings. Clears the entry selected by the cursor and opens the field for character entry. Also operable in the identification mode to enter the self-test mode.

3.32 CURSOR: Selects the cursor operation of the tape/cursor key switches. When indicator is lit the cursor (lower) legends are in effect.

3.33 SCROLL \wedge (Up): Operable in the capture mode to initiate upward movement of displayed data. Movement continues as long as switch is pressed. Also operable in the run mode to step through the transmission code selections for both DTE and DCE sides of the line. During tape playback when scrolling reaches the end of the capture buffer, initiates reading the next block of data from the tape.

3.34 SCROLL HOME: Operable in the capture mode to have the displayed data with line one of the capture buffer on line three of the display.

3.35 SCROLL \vee (Down): Operable in the capture mode to initiate downward movement of displayed data. Movement continues as long as switch is pressed. Also operable in the run mode to step through the DCE transmission code selections.

3.36 BIT SHIFT: Operable in the capture mode to shift the data in the video buffer one bit to the left.

3.37 ENTER: Operable in the manual step mode to terminate character or bit string entries. Also operable to terminate a step scroll value in the capture mode.

C. Hexadecimal Keys

3.38 0 thru F: Permit entry of the hexadecimal character strings, required for configuration page entries, when the HEX PAD indicator is lit.

D. Tape Keys

3.39 The tape keys are operable when the TAPE indicator is lit.

3.40 PLAYBACK: Initiates playback of the tape in accordance with the

SECTION 3

parameters selected on the tape configuration page.

3.41 RECORD: Initiates the run mode and real-time recording when the record function is enabled.

3.42 STOP: Aborts operation of other tape functions.

3.43 REWIND: Initiates rewind of the tape. Following rewind, the tape is positioned at the beginning of track 1.

3.44 FAST FORWARD: Initiates fast-forward motion of the tape. When the end of track is reached the tape is positioned at the beginning of track 2.

E. Cursor Keys

3.45 The cursor keys are operable when the CURSOR indicator is lit.

3.46 Up(Λ): Initiates upward movement of the cursor. In the capture mode movement is vertical from one line to the next. In the configuration displays, movement is from field to field. Movement continues as long as the switch is pressed. From the top line on the display the cursor wraps around to the bottom line.

3.47 Down(V): Operation the same as the cursor up switch except movement is downward.

3.48 HOME: Moves the cursor to the upper left character position on the display.

3.49 Left(<): Initiates leftward movement of the cursor. In the capture mode movement is leftward from one character position to the next. In the configuration displays movement is from field to field. Movement continues as long as the key is pressed. From the left side of the display the cursor wraps around to the right side of the previous line.

3.50 Right(>): Operation the same as the cursor left switch except movement is rightward.

F. Power Switch

3.51 Power: Alternate-action push-button switch; controls application of power to the unit. Provides an indication when the switch is activated.

G. Rear Panel

3.52 CURRENT LOOPS: 25-pin female EIA connector; provides current loop interfaces for a remote teletypewriter.

3.53 DATA INTERFACE: 25-pin female EIA connector; provides interconnections to data circuit-terminating equipment (DCE), using RS-232-C interface.

3.54 B & W: Female BNC connector; provides composite video output for display of the monitor CRT display on a remote video monitor.

3.55 SYN: Female BNC connector; provides the synchronizing signal for a remote color video monitor.

3.56 RED, GRN, BLU: Female BNC connectors; provide red, green, and blue chrominance video signals for a color display on a color video monitor.

3.57 Line: Three-prong male connector; provides interconnection to ac power line.

4. AUTOMONITOR™ MODE

4.01 Data link monitoring is performed automatically. All that is required is to connect the monitor to a power source and to the interface, as described in section 2, and turn on the unit by pressing the power switch. The monitor performs a series of self-tests; then enters the line identification mode. While in this mode the display indicates AUTOMONITOR IN PROGRESS, PRESS PAGE FOR MANUAL STEP, CLEAR TO ENTER SELF TEST. The self-test mode could be

entered at this time by pressing CLEAR. (Refer to paragraph 13.01.) As data is received from both sides of the line the monitor searches for the line configuration parameters. When the parameters from the one side of the line are detected, the other side is defaulted to the same condition, and operation enters the run mode. Normally this occurs in a few seconds. The monitor and display configuration parameters assume the default conditions at this time.

5. MONITOR FUNCTION

5.01 In the monitor function of the run mode the data received by the monitor is logged into the capture buffer and displayed on the screen. Several operations are available that permit analysis of the received data or alteration of the monitor parameters. These operations include freeze, code/hex, capture, transparent sync, resync, turnaround time, mark, and transmission code selection.

5.02 Freeze. In the freeze operation the data in the video display is frozen. Accumulation of data in the capture buffer does not stop. To freeze the display, press FREEZE/RESUME. Press again to resume the display of real-time data.

5.03 Code/Hex. The received data is normally displayed as characters. To display the hexadecimal equivalents, press CODE/HEX. Press again to return display to real-time data.

5.04 Capture. The capture mode stops the logging and display of received data. To enter the capture mode press CAPTURE. The operations that can be performed in the capture mode are described in part 6 of this section. To return to the run mode, press RUN.

5.05 Transparent Sync. In synchronous protocols the monitor searches for sync characters before logging data. Pressing TRANSP SYNC, allows logging and display of the data

without detection of the sync characters. The applicable line configuration parameters must be defined in the manual step mode, and the run mode selected before this operation can be performed. The displayed data will not be synchronized, however. The capture mode can be entered, and bit-shift operation, as described in paragraph 6.06, can be used to decipher the message.

5.06 Resync. After data synchronization has been achieved in synchronous protocols, synchronization can be broken by pressing RESYNC. Logging and display of data stops until synchronization is restored with detection of the next sync characters in the received data.

5.07 Turnaround Time. Turnaround time is measured in bisync protocol and is the time between the last character received in a transmission from the DCE side of the line to the first sync character received from the DTE side and between the last character received from the DTE side of the line and the first sync character received from the DCE side. These measurements can be performed by the monitor in real time, and the calculated value displayed on the screen with the received data. With operation in the monitor function of the run mode, press TURN AROUND to calculate the turnaround times. The time multiplex display mode is automatically entered, and the calculated times are displayed, in milliseconds, in the space between the DCE and DTE data blocks on the screen. The time between the DCE and DTE blocks is displayed as normal characters in bright intensity. The time between the DTE and DCE blocks is displayed as reverse characters in bright intensity. To delete the turnaround time press TURN AROUND again.

5.08 Mark. The mark operation provides a means of manually identifying, on the display, a portion of the data stream as it is received. To initiate the mark condition, when

SECTION 3

operating in the monitor function of the run mode, press MARK. A blinking line appears under each received character as it is displayed on the screen. Press MARK again to stop the mark condition. The blinking underline attribute remains active on the display and in the capture buffer as long as the data is available. This aids in locating specific data when in the capture mode.

5.09 Transmission Code Selection. The transmission code selection operation permits manual selection of alternate transmission codes for use in displaying the received data. Separate selections can be made for each side of the line, and changes are made in real time. To perform this operation when operating in the monitor function of the run mode, press the SCROLL up key. The capture buffer and the display are cleared and the next selectable transmission code is identified on the top lines of the display. Subsequent data for both DTE and DCE sides of the line are logged and displayed using this code. Continuing to press SCROLL up repeats this action for each available code. None of the other parameters, including bits per character, are affected by this action. To perform this operation separately for the DCE side of the line, press SCROLL down. Operation is identical to the selection, except the code identification is performed on the second line of the display, and the DCE data is logged and displayed using this code.

6. CAPTURE MODE

6.01 The capture mode is entered from the run mode of the monitor function, by pressing the CAPTURE key. In this mode logging of data into the capture buffer is stopped and the captured data is displayed with the earliest received data displayed first, with the first line of data displayed on the third line of the display. A blinking cursor identifies the first character of data on the first line. This display is the home position. The top line on the

screen displays the scroll line number of the first displayed line of data and the bit pattern for the cursored character. The second line of the display identifies, by type, any errors in the cursored character. Several operations are available in the capture mode that aid in analysis of the received data. These operations include code/hex, manual step, scroll, cursor, bit shift, event count, and default.

6.02 Code/Hex. The CODE/HEX key operates in the capture mode in the same manner as described for the monitor function of the run mode. (Refer to paragraph 5.03.)

6.03 Manual Step. The display mode and display size parameters can be changed in the manual step mode, and the changes reflected in the captured data. These changes are performed as described in paragraphs 7.38 and 7.39. After selecting the desired display conditions, pressing CAPTURE will return the capture display. The selected conditions will be in effect.

6.04 Scroll. The capture display only shows a portion of the data stored in the capture buffer. All the data can be sequentially viewed by scrolling through the stored data. Press the SCROLL up key to scroll the data upward two lines on the screen. Press SCROLL down to scroll the data downward on the screen. As the data scrolls two lines the line number, displayed on the first line of the screen, changes to indicate the line number of the first line of data currently being displayed. To return the display to the home position, press SCROLL HOME.

6.05 Automatic scrolling can be initiated by pressing SHIFT followed by SCROLL up or SCROLL down. Scrolling will continue until the end of the capture buffer is reached unless stopped by pressing SCROLL up or SCROLL down a second time.

6.06 A step-scroll operation permits stepping through the captured data by a selected number of lines. This operation is performed as follows:

- (a) Press STEP to open the step selection and clear any existing entry.
- (b) Enter the number of lines desired to step.

NOTE: Scrolling will not exceed the data in the capture buffer. If a step number is entered that exceeds the data, scrolling will step to the last page of data and stop.

- (c) Press ENTER to terminate the entry.
- (d) Press SCROLL up to advance the displayed data or SCROLL down to regress it. The displayed data will advance or regress by the number of lines selected.

NOTE: The step operation remains enabled until reset by entering a new step value. The default value is two.

6.07 Cursor. The initial position of the cursor is on the first data character on the display: the left-most character on the third line on the screen. Using the CURSOR keys, the cursor can be moved to any data position on the screen. The CURSOR left, right, up, and down keys move the cursor in the direction indicated by the arrows. As the cursor is moved the bit pattern and error indications on the top of the screen change to indicate the status of the cursor character. Pressing the CURSOR HOME key returns the cursor to the home position on the displayed data.

6.08 Bit Shift. The display may sometimes show legible data that suddenly becomes garbled. This is frequently due to bit-shifting in the

transmitted data stream, and is usually caused by transient hits on the transmission lines. The bit-shifting function can be used to decipher the message or locate the shifted bit. To perform this operation press the BIT SHIFT key. The data in the video buffer shifts one bit to the left. (The data bits within each word frame are shifted to the right.) Repeated pressing shifts the display through the character length, and the original characters are displayed, shifted left one position.

6.09 Reset. The automatic line identification mode can be repeated at anytime during operation by pressing RESET. All parameters are returned to the default conditions, and the monitor repeats the search for the line parameters.

7. MANUAL STEP MODE

7.01 The monitor performs automatic signal detection and line synchronization. Provision is made, however, to manually select the line configuration parameters in the manual step mode. The monitor and display parameters can also be manually selected in this mode. Selection of these parameters is performed on two configuration pages. A third configuration page provides selection and display capability for the monitor function counters.

A. Line Configuration Parameters

7.02 The following paragraphs provide step-by-step instructions for manual selection of the parameters associated with the input data. These parameters are selectable on the line/display configuration page and include the following parameters: protocol, bit rate, transmission code and number of bits, parity, CRCC polynomial, sync characters, resync characters, data channel assignment, data sense, data bit order, and data encoding.

7.03 Protocol. To manually select the line protocol proceed as follows:

SECTION 3

(a) From the line identification mode press PAGE to display the configuration page menu.

Note: If operation is in the run mode it will be necessary to enter the capture mode by pressing CAPTURE before the manual step mode can be entered.

(b) Press 1 to select the line/display configuration page. The line display configuration page is displayed. (See figure 2.)

(c) Using the CURSOR keys, position the blinking cursor in the reverse-video, PROTOCOL field.

(d) Press the STEP key until the desired protocol is displayed. Each available protocol is sequentially displayed as STEP is pressed.

(e) As each protocol is selected the remaining line parameters are automatically changed to the default conditions for that protocol. If these conditions meet the requirements of the interface, proceed to the run mode by pressing RUN.

(f) If the default conditions for the selected protocol do not meet the requirements of the interface, continue with the following procedures as required.

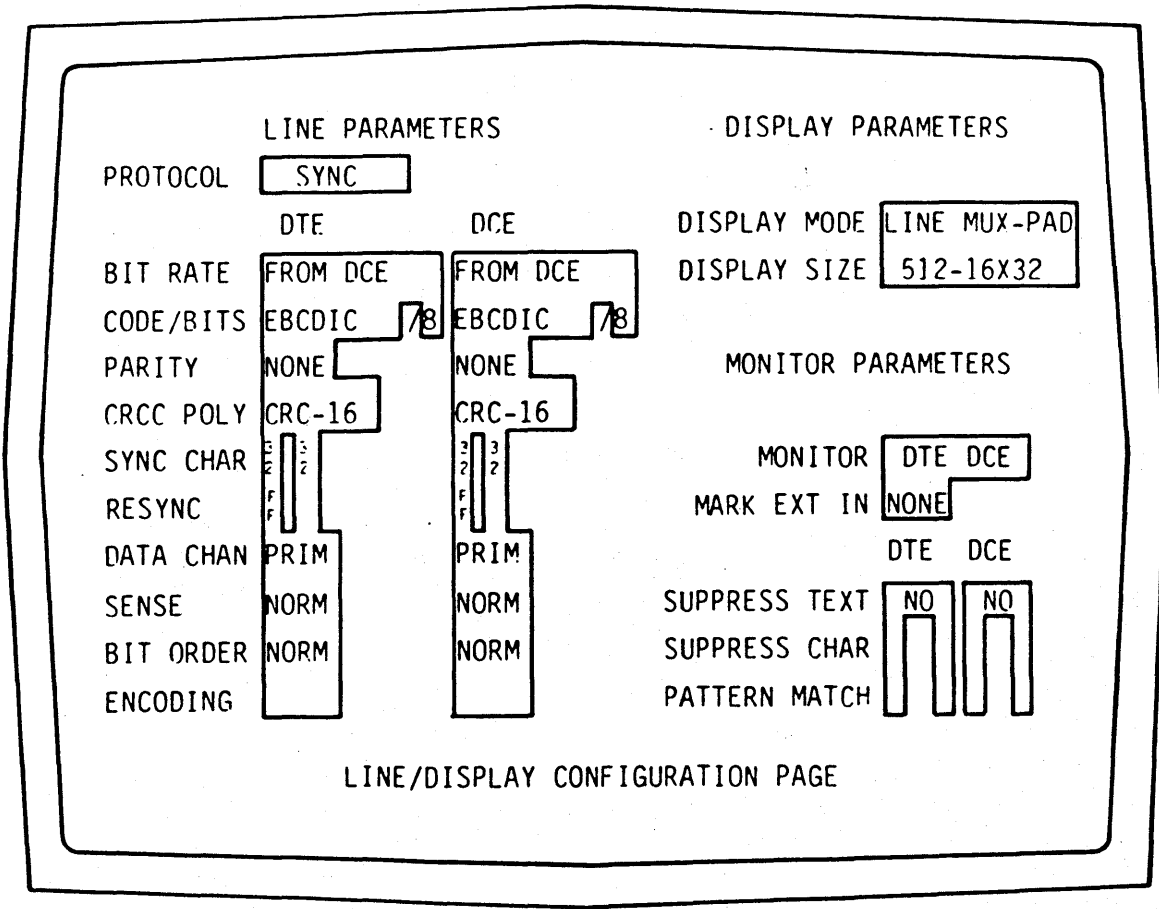

Figure 2. Line/Display Configuration Page

7.04 Bit Rate. Separate bit rates may be selected for the DTE and DCE sides of the line. To manually select either or both bit rates proceed as follows:

- (a) From the line identification mode press PAGE to display the configuration page menu.
- (b) Press 1 to select the line/display configuration page. (See figure 2.)
- (c) To change the DTE bit rate, position the cursor in the reverse-video, BIT RATE field under DTE.
- (d) Press the STEP key until the desired condition is displayed. As STEP is pressed, each available condition is sequentially displayed, for both DTE and DCE sides of the line.

Note: Changes to the DTE are also reflected in the DCE. Therefore, if different conditions are required, the DCE must be selected after the DTE.

- (e) If a different condition is to be selected for the DCE side of the line, position the cursor in the field under DCE.
- (f) Press the STEP key until the desired condition is displayed.
- (g) If the displayed conditions for the remaining line parameters meet the requirements of the interface, proceed to the run mode by pressing RUN.
- (h) If the displayed conditions do not meet the requirements, continue with the following procedures as required.

7.05 Transmission Code. Separate transmission codes may be selected for the DTE and DCE sides of the line. Manual selection of the transmission codes is performed in a manner similar to that

for bit rates. Position the cursor in the left reverse video CODE/BITS field under DTE and proceed as described in paragraph 7.04, steps (d) through (h). The default bit per character values for each code are automatically selected with the code selection. To select a different number of bits, proceed as described in the following paragraph. To return to the run mode, press RUN.

7.06 Bit Per Character. Separate bit per character values may be selected for the DTE and DCE sides of the line. Manual selection of the bit per character values is performed in a manner similar to that for bit rates. Position the cursor in the right reverse video CODE/BITS field under DTE and proceed as described in paragraph 7.04, steps (d) through (h).

7.07 Parity. Parity may be used with any transmission code. Separate parity selections can be made for the DTE and DCE sides of the line in a manner similar to that for bit rates. Position the cursor in the reverse video parity field under DTE and proceed as described in paragraph 7.04, steps (d) through (h).

7.08 CRCC Polynomial. The CRCC polynomial is only applicable with synchronous protocols. Separate polynomials can be selected for the DTE and DCE sides of the line in a manner similar to that for bit rates. Position the cursor in the reverse video CRCC polynomial field under DTE and proceed as described in paragraph 7.04, steps (d) through (h).

7.09 Sync Characters. Sync characters are only applicable with synchronous protocols. Separate selections can be made for the DTE and DCE sides of the line as follows:

- (a) From the line identification mode press PAGE to display the configuration page menu.
- (b) Press 1 to select the line/display configuration page. The line/display configuration page is displayed. (See figure 2.)

SECTION 3

(c) To change the DTE sync characters position the cursor in the first (left), reverse-video, SYNC CHAR space under DTE.

(d) Press CLEAR to delete the existing entries and open the selection. The existing sync character entries for both DTE and DCE are deleted, and the HEX PAD indicator lights.

(e) Using the hexadecimal keys, enter the two-digit, hexadecimal code for the first sync character. The first sync character is displayed for both the DTE and DCE sides of the line, and the cursor moves to the second character space.

Note: If an erroneous key is pressed, complete the character entry, then press ENTER to terminate the selection. Using the CURSOR keys, position the cursor over the erroneous character and press CLEAR to delete the entry; then reenter.

(f) Enter the two digit hexadecimal code for the second sync character. The second character is displayed for both the DTE and DCE sides of the line.

(g) To enter different characters for the DCE side of the line, move the cursor to the first space under DCE and repeat steps (d) through (f). The sync characters for the DCE are displayed as entered.

(h) If the display conditions for the remaining line parameters meet the requirements of the interface, proceed to the run mode by pressing RUN.

(i) If the displayed conditions do not meet the requirements, continue with the following procedures as required.

7.10 Resync. Resync characters are only applicable with synchronous protocols. Separate selections can be made for DTE and DCE sides of the line in a manner similar to that for sync

characters. Position the cursor in the first (left) reverse-video, RESYNC space under DTE and proceed as described in paragraph 7.09, steps (c) through (h).

7.11 Data Channel. Primary (PRIM), secondary (SEC), and current loop (CRLP) data channel selections are provided. Separate selections can be made for DTE and DCE sides of the line in a manner similar to that for bit rates. Position the cursor in the reverse video DATA CHANNEL field under DTE and proceed as described in paragraph 7.04, steps (d) through (h).

7.12 Data Sense. Normal and inverted data sense selections are provided. Separate selections can be made for DTE and DCE sides of the line in a manner similar to that for bit rates. Position the cursor in the reverse video DATA SENSE field under DTE and proceed as described in paragraph 7.04, steps (d) through (h).

7.13 Data Bit Order. Normal and reverse data bit order selections are provided. Separate selections can be made for the DTE and DCE sides of the line in a manner similar to that for bit rates. Position the cursor in the reverse video DATA BIT ORDER field under DTE and proceed as described in paragraph 7.04 and steps (d) through (h).

7.14 Data Encoding. Data encoding selections include direct and non-return-to-zero-inverting (NRZI). Separate selections can be made for the DTE and DCE sides of the line in a manner similar to that for bit rates. Position the cursor in the reverse video DATA ENCODING field under DTE and proceed as described in paragraph 7.04, steps (d) through (h).

B. Monitor Configuration Parameters

7.15 The following paragraphs provide step-by-step instructions for manual selection of the parameters associated with monitoring the received data. These parameters are selectable on the line/display and start/stop configuration pages and include the following parameters: monitor, mark external EIA

input, suppress text, suppress characters, start/stop function, and start/stop triggers.

7.16 Monitor. The monitor parameter permits monitoring the DTE, DCE, or both the DTE and DCE sides of the line. The default condition is DTE and DCE. To select a different condition proceed as follows:

- (a) From the line identification mode press PAGE to display the configuration page menu.

Note: If operation is in the run mode it will be necessary to enter the capture mode by pressing CAPTURE before the manual step mode can be entered.

- (b) Press 1 to select the line/display configuration page. The line/display configuration page is displayed. (See figure 2.)

- (c) Using the CURSOR keys position the cursor in the reverse-video, MONITOR field.

- (d) Press the STEP key until the desired condition is displayed. Each condition is sequentially displayed as STEP is pressed.

7.17 Mark External EIA Input. This parameter permits monitoring of a selected EIA lead and marking of the displayed data upon the occurrence of a positive transition (UP), negative transition (DOWN), marking (MARK) condition, or spacing (SPACE) condition. The default condition is NONE. Selection is similar to monitor selection described in paragraph 7.16. Position the cursor in the MARK EXT. EIA IN field and press STEP to display the desired condition.

7.18 Suppress Text. This parameter offers the option of suppressing storage and display of text from the received data. Separate selections can be made for the DTE and DCE sides of the line. The default condition is NONE. To select text suppression for either or both sides of the line proceed as follows:

- (a) From the line identification mode press PAGE to display the configuration page menu.

- (b) Press 1 to select the line/display configuration page. The line/display configuration page is displayed. (See figure 2.)

- (c) To select DTE text suppression, position the cursor in the reverse video SUPPRESS TEXT field under DTE.

- (d) Press the STEP key to display YES.

Note: Changing the DTE is also reflected in the DCE. Therefore, if different conditions are required, the DCE must be selected after the DTE.

- (e) If a different condition is to be selected for the DCE side of the line, position the cursor in the field under DCE.

- (f) Press the STEP key to display the desired condition.

7.19 Suppress Characters. This parameter allows storage and display suppression of two characters each from the received data on the DTE and DCE sides of the line. The default condition is no character suppression. To select character suppression on either or both sides of the line proceed as follows:

- (a) From the line identification mode press PAGE to display the configuration page menu.

- (b) Press 1 to select the line/display configuration page. The line/display configuration page is displayed. (See figure 2.)

- (c) To select DTE character suppression, position the cursor in the first (left), dim-video, SUPPRESS CHAR space under DTE.

- (d) Press CLEAR to delete any existing entries and to open the selection.

SECTION 3

Any existing entries are deleted and the HEX PAD indicator lights.

(e) Using the hexadecimal keys, enter the two-digit, hexadecimal code for the first character you want to suppress. The first character is displayed, for both the DTE and DCE, and the cursor moves to the second character space.

Note: If an erroneous key is pressed, complete the character entry, then press ENTER to terminate the selection. Using the CURSOR keys, position the cursor over the erroneous character and press CLEAR to delete the entry, then re-enter.

(f) If only one character selection is to be made for the DTE side of the line, press ENTER to terminate the selection and proceed with step (h). To enter a second character continue with step (g).

(g) Enter the two-digit, hexadecimal code for the second character to be suppressed. The second character is displayed. Selection is automatically terminated following entry of the second character; therefore, it is not necessary to press ENTER.

(h) To enter different characters for the DCE side of the line, move the cursor to the first space under DCE and repeat steps (d) through (g). The characters for the DCE are displayed as entered.

7.20 Pattern Match. This parameter permits monitoring of the received data for a one or two character pattern and indicating the occurrence of a pattern match by a flashing underline of the data in the display. Separate selections can be made for the DTE and DCE sides of the line in a manner similar to that for suppress characters. Position the cursor in the first, dim-video, PATTERN MATCH space under DTE and proceed as described in paragraph 7.19, steps

(d) through (h). Selecting these parameters also enable the associated pattern counters on the counter configuration page. (Refer to paragraph 7.40.)

Note: If a two-character pattern is selected only the second character is underlined.

7.21 Start/Stop Function. This parameter permits selection of the type of start/stop function to be performed by the monitor. Monitor, time-out-stop, elapsed seconds, elapsed milliseconds, and elapsed characters selections are provided. The default condition is monitor. To select a different function proceed as follows:

(a) From the line identification mode press PAGE to display the configuration page menu.

(b) Press 2 to select the async-BCP or the BOP start/stop configuration page. (See figures 3 and 4.)

Note: The start/stop configuration page displayed will conform to the protocol selected on the line/display configuration page as described in paragraph 7.03.

(c) Position the cursor in the reverse video, FUNCTION field.

(d) Press the STEP key until the desired function is displayed.

7.22 External Input. This parameter permits monitoring of a selected EIA lead, patched to the EIA IN jack, for use as a start trigger. The trigger conditions are a marking (MARK) or spacing (SPACE). The default condition is NONE. Selection is similar to start/stop function described in paragraph 7.21. Position the cursor in the reverse-video, EXT IN field in the start/stop configuration page and press STEP to display the desired condition.

7.23 Start Strings. This parameter enables monitoring of the received

data for start strings A, B, and C and allows selection of AND or OR logic combinations of these strings as a start trigger. The default condition is NONE. Selection is similar to the start/stop function described in paragraph 7.21. Position the cursor in the reverse-video, START STRINGS field on the start/stop configuration page and press STEP to display the desired condition.

7.24 A, B, and C Start Strings. These parameters are associated with async and byte-controlled protocols and provide entry for up to six data

strings, of up to eight characters each, for use as start triggers. Three separate strings can be entered for monitoring each side of the line. Selections of OR and independent (IND) logic combinations for the two sides of the line are provided. To enter a string proceed as follows:

- From the line identification mode press PAGE to display the configuration page menu.
- Press 2 to select the async-BCP start/stop configuration page.

FUNCTION <input style="width: 100%;" type="text"/>	STOP ALARM <input style="width: 100%;" type="checkbox"/>	TRIGGER COUNT <input style="width: 100%;" type="text"/>
	STOP ON ERROR <input style="width: 100%;" type="checkbox"/>	POSTRIG COUNT <input style="width: 100%;" type="text"/>
		TIMEOUT VALUE <input style="width: 100%;" type="text"/>
START TRIGGER: <input style="width: 100%;" type="text"/>		
START STRINGS <input style="width: 100%;" type="checkbox"/>	EXT IN <input style="width: 100%;" type="text"/>	
A STRING	DTE	DCE
B STRING		
C STRING		
STOP TRIGGER: <input style="width: 100%;" type="text"/>		
STOP STRINGS <input style="width: 100%;" type="checkbox"/>	CLK/EXT2 IN <input style="width: 100%;" type="text"/>	
A STRING	DTE	DCE
B STRING		
C STRING		
ERROR ASYNC-BCP START/STOP CONFIGURATION PAGE		

Figure 3. Async-BCP Configuration Page

SECTION 3

- (c) Position the cursor in the first (left), dim-video, A STRING field under DTE or DCE as required.
- (d) Press CLEAR to delete any existing entries and to open the selection. Any existing entries are deleted, and the HEX PAD indicator lights.
- (e) Using the hexadecimal keys, enter the two-digit, hexadecimal code for the first character of the start

string. The first character is displayed and the cursor moves to the second character space.

Note: If an erroneous key is pressed, complete the character entry; then press ENTER to terminate the selection. Position the cursor over the erroneous character, and press CLEAR to delete the entry; then reenter.

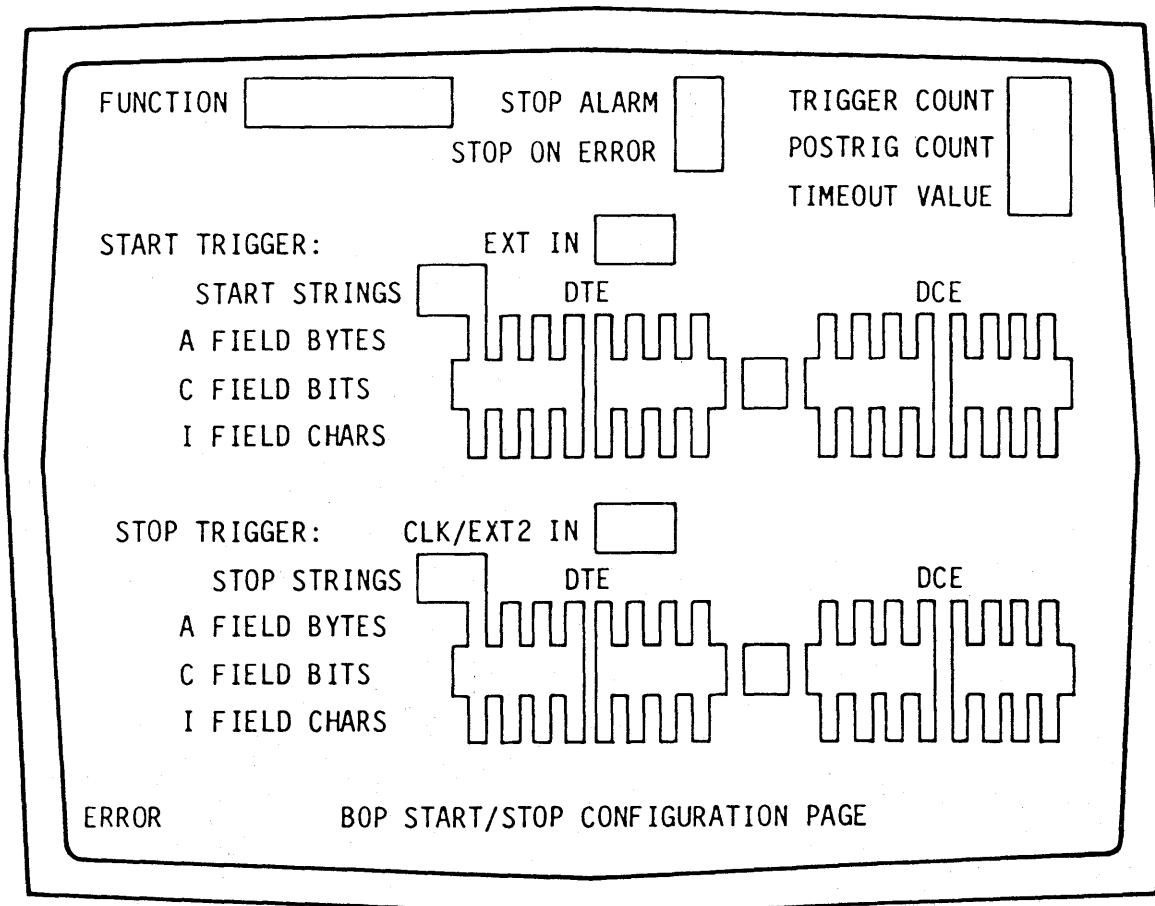

Figure 4. BOP Configuration Page

(f) Continue entering the hexadecimal codes for each character in the string.

Note: The DON'T CARE key can be used to provide a nondefinitive entry at any point in the string. In this case a dim X is shown in reverse-video in the display.

(g) If less than eight characters are required in the string, press ENTER to terminate the selection. Selection is automatically terminated following entry of the eighth character, in which case it is not necessary to press ENTER.

(h) To enter additional start strings repeat steps (c) through (g) for the additional strings under both DTE and DCE fields.

(i) Position the cursor to the reverse video field between the DTE and DCE fields.

(j) Press the STEP key until the desired logic condition is displayed.

7.25 To delete a previously entered string proceed as follows:

(a) Repeat steps (a) through (d) from paragraph 7.24 for the string to be deleted.

(b) Press ENTER to terminate the selection.

(c) Proceed with any other changes required to the start/stop configuration page or press RUN to return to the run mode.

7.26 A, C, and I Start Strings. These parameters are associated with bit-oriented protocols and provide entry for six data strings for use as start triggers. Three separate strings can be entered for monitoring each side of the line. Selections of OR or independent (IND) logic combinations for the two

sides of the line are provided. The A-field byte and I-field character strings are eight character strings and are entered in a manner similar to A, B, and C start strings. Position the cursor in the first (left), dim-video field for the respective parameter and proceed as described in paragraph 7.24, steps (d) through (g). The logic condition is selected as described in paragraph 7.24, steps (i) and (j). The C-field bit string is a 16-bit, binary string and is entered as follows:

(a) From the line identification mode press PAGE to display the configuration page menu.

(b) Press 2 to select the BOP start/stop configuration page.

(c) Position the cursor at the left of the dim-video, start string C FIELD BITS field under DTE or DCE as required.

(d) Press CLEAR to delete any existing entries and to open the selection. Any existing entries are deleted, and the HEX PAD indicator lights.

(e) Using the 0, 1, and DON'T CARE keys, enter the binary bit string. Each bit is displayed as entered.

Note: If an erroneous key is pressed, press ENTER to terminate the selection. Position the cursor over erroneous bit and press clear to delete the entry; then re-enter.

(f) If less than 16 bits are required in the string, press ENTER to terminate the selection. Selection is automatically terminated following entry of the sixteenth bit, in which case it is not necessary to press ENTER.

(g) Repeat steps (c) through (f) for the other side of the line if required.

SECTION 3

7.27 Clock/External 2 Input. This parameter permits monitoring of a selected EIA lead, patched to the CLK/EXT2 jack, for use as a stop trigger. The trigger conditions are a positive transition (DOWN), marking (MARK), or spacing (SPACE). The default condition is NONE. Position the cursor in the reverse-video CLK/EXT2 IN field in the start/stop configuration page and press STEP to display the desired condition.

7.28 Stop Strings. This parameter enables monitoring of the received data for the stop strings and allows selection of AND or OR logic combinations of these strings as a stop trigger. A FLAG selection is also provided for bit-oriented protocols. The default condition is NONE. Position the cursor in the reverse-video, STOP STRINGS field on the start/stop configuration page and press STEP to display the desired condition.

7.29 A, B, and C Stop Strings. These parameters are associated with async and byte-controlled protocols and provide entry for up to six data strings, of up to eight characters each, for use as stop triggers. Three separate strings can be entered for monitoring each side of the line. Selections of OR or independent (IND) logic combinations for the two sides of the line are provided. Entry of each string is similar to the A, B, and C start strings. On the start/stop configuration page, position the cursor in the first (left), dim-video field corresponding to the desired string and data source; then enter the strings and logic condition as described in paragraph 7.24, steps (d) through (j).

7.30 A, C, and I Stop Strings. These parameters are associated with bit oriented protocols and provide entry for six data strings for use as stop triggers. Three separate strings can be entered for monitoring each side of the line. Selections of OR and independent (IND) logic combinations for the

two sides of the line are provided. The C-field bit strings are 16-bit, binary strings and are entered in a manner similar to the C start string. Position the cursor at the left of the dim-video, STOP STRING C FIELD BITS field under DTE or DCE, as required, and enter the binary bit string as described in paragraph 7.26, steps (c) through (g). Repeat the entry for the other side of the line if required. The A- and I-field character strings are eight-character strings and are entered in a manner similar to the A, B, and C start strings. On the start/stop configuration page, position the cursor in the first (left), dim-video field under DTE or DCE, as required, and enter the character string as described in paragraph 7.24, steps (d) through (j).

7.31 BCC Error. This parameter is associated with bisync protocol and enables detection of a block check character (BCC) error to be used as a stop trigger. The default condition is NO. To enable this function, position the cursor in the BCC ERROR field in the start/stop configuration page and press the STEP key to display YES.

7.32 FCS Error. This parameter is associated with BOP protocols and enables detection of a frame check sequence (FCS) error to be used as a stop trigger. The default condition is NO. To enable this function, position the cursor in the FCS ERROR field in the start/stop configuration page and press the STEP key to display YES.

7.33 Alarm. This parameter enables the alarm to sound upon the occurrence of a stop trigger. The default condition is NO. To enable the alarm, position the cursor in the ALARM field in the start/stop configuration page and press the STEP key to display YES. To turn off the alarm following a trigger, press CLEAR.

7.34 Trigger Count. This parameter permits performance of the

selected start/stop function up to 9,999 times. The function is repeated continuously if no entry is made or if 0000 is entered. To enter a value for this parameter proceed as follows:

- (a) With the start/stop configuration page displayed, position the cursor in the TRIGGER COUNT field.
- (b) Press CLEAR to delete any existing value and to open the selection. Any existing value is deleted, and the HEX PAD indicator lights.
- (c) Using the hexadecimal keys enter the desired time as a decimal value up to 9,999.
- (d) To delete an existing entry, position the cursor in the RESUME COUNT field, press CLEAR to delete the existing value; then press ENTER to terminate the selection.

Note: If an erroneous key is pressed, press ENTER to terminate the selection and press CLEAR to delete the entry; then re-enter.

7.35 Post-Trigger Count. This parameter permits storage and display of up to 9,999 characters following the stop trigger. It should be noted that entering a value greater than the size of the capture buffer will result in overflow and loss of the trigger data. To enter a post-stop count, position the cursor in the POSTRG COUNT field and proceed as described in paragraph 7.34, steps (b) and (c). To delete an existing entry, position the cursor in the POSTRG COUNT field, press CLEAR to delete the existing value; then press ENTER to terminate the selection.

7.36 Timeout Value. This parameter permits entry of a time, in seconds, to be used as a stop trigger in the start/stop and timeout-stop functions. This time is measured from the occurrence of the start trigger. No entry or entering 0000 results in continuous operation. Entering a timeout value also enables the timeout

counter on the counter configuration page. To enter a value for this parameter position the cursor in the TIMEOUT VALUE field and proceed as described in paragraph 7.34 steps (b) and (c). To delete an existing entry, position the cursor in the TIMEOUT VALUE field, press CLEAR to delete the existing value; then press ENTER to terminate the selection.

C. Display Configuration Parameters

7.37 The following paragraphs provide step-by-step instructions for manual selection of the parameters associated with display of the received data. These parameters are selectable on the line/display configuration page and include display mode and display size.

7.38 Display Mode. This parameter permits selection of the display mode including LINE MUX (line multiplex without pad characters), LINE MUX-PAD (line multiplex with pad characters), TIME MULTIPLEX, DISPLAY DTE, and DISPLAY DCE. The default condition is LINE MUX-PAD. To select a different condition proceed as follows:

- (a) From the line identification or capture mode press PAGE to display the configuration page menu.

Note: If operation is in the run mode it will be necessary to enter the capture mode by pressing CAPTURE before the manual step mode can be entered.

- (b) Press 1 to select the line/display configuration page. (See figure 2.)

- (c) Using the CURSOR keys position the blinking cursor in the reverse-video, display mode field.

- (d) Press the STEP key until the desired condition is displayed. Each condition is sequentially displayed as STEP is pressed.

SECTION 3

7.39 Display Size. This parameter permits selection of the size of the data display. Selections include 512 characters consisting of 16 lines of 32 characters each (512-16x32) and 1024 characters consisting of 16 lines of 64 characters each (1024-16x32). The default condition is 512. Selection of a different condition is similar to display mode selection described in paragraph 7.38. Position the cursor in the DISPLAY SIZE field and press STEP to display the desired condition.

D. Counter Functions

7.40 Thirty-three, function-designated counters are provided with the monitor. These counters are accessed through the counter configuration page. The counters applicable to the selected protocol are identified by a reverse-video field. The default condition of each of these counters is disabled (DSABL). The pattern and timeout counters are enabled by selection of the respective monitor configuration parameters. (Refer to paragraphs 7.20 and 7.31.) To enable a counter proceed as follows:

- (a) From the line identification or capture mode press PAGE to display the configuration page menu.

Note: If operation is in the run mode it will be necessary to enter the capture mode by pressing CAPTURE before the manual step mode can be entered.

- (b) Press 3 to select the counter configuration page. (See figure 5.) The applicable counters are identified by the word DSABL in a reverse-video field following the counter name on the page.
- (c) Using the CURSOR keys position the blinking cursor in the reverse-video field corresponding to the counter to be enabled and press STEP to display 00000. The selected counter is now enabled.

- (d) Repeat step (c) for each additional counter to be enabled.

- (e) To perform the selected counts in real time, enter the run mode by pressing RUN.

8. START/STOP FUNCTION

8.01 The start/stop function is subordinate to the monitor function described in part 5. In this function, however, start and/or stop triggers control the logging of data. The line configuration parameters must be defined, either automatically in the line identification mode or manually in the manual step mode, before this function can be performed. To perform this function proceed as follows:

- (a) Select the MONITOR start/stop function as described in paragraph 7.21.

- (b) If an external EIA input is to be used as a start trigger, select the condition as described in paragraph 7.22 and patch the applicable lead to the EXT IN jack on the EIA line interface section.

- (c) If start strings are to be used as start triggers, select the desired combination of the strings as described in paragraph 7.23. Enter the start strings as described in paragraph 7.24 for async and bisync protocols or in paragraph 7.26 for BOP protocols.

- (d) If an external EIA input is to be used as a stop trigger, select the condition as described in paragraph 7.27 and patch the applicable lead to the CLK/EXT2 jack on the EIA line interface section.

- (e) If stop strings are to be used as stop triggers, select the desired combination of the strings as described in paragraph 7.29 for async and bisync protocols or 7.30 for BOP protocols.

(f) If a BCC or FCS error is to be used as a stop trigger, enable the parameter as described in paragraph 7.31 or 7.32.

(g) If an alarm following the occurrence of a stop trigger is desired, enable the alarm as described in paragraph 7.33.

(h) If the start/stop operation is to be performed a limited number of times, enter the trigger count value as described in paragraph 7.34.

(i) If it is desired that data be logged following the stop trigger,

enter the post-trigger count as described in paragraph 7.35.

(j) If a timeout value is to be used as a stop trigger, enter the timeout value as described in paragraph 7.36. This also enables the timeout counters on the counter configuration page.

(k) To execute this function press RUN. The monitor logs and displays data in accordance with the parameters entered and, following the last stop trigger, enters the capture mode. All the capture operations described in part 6 are applicable.

	DTE	DCE		DTE	DCE
FRAMING ERRORS	<input type="checkbox"/>	<input type="checkbox"/>	CHARACTER COUNT	<input type="checkbox"/>	<input type="checkbox"/>
PARITY ERRORS	<input type="checkbox"/>	<input type="checkbox"/>	BLOCK COUNT	<input type="checkbox"/>	<input type="checkbox"/>
BCC ERRORS	<input type="checkbox"/>	<input type="checkbox"/>	FRAME COUNT	<input type="checkbox"/>	<input type="checkbox"/>
FCS ERRORS	<input type="checkbox"/>	<input type="checkbox"/>			
NOT MOD8 ERRORS	<input type="checkbox"/>	<input type="checkbox"/>	A STOP STRINGS	<input type="checkbox"/>	<input type="checkbox"/>
			B STOP STRINGS	<input type="checkbox"/>	<input type="checkbox"/>
A START STRINGS	<input type="checkbox"/>	<input type="checkbox"/>	C STOP STRINGS	<input type="checkbox"/>	<input type="checkbox"/>
B START STRINGS	<input type="checkbox"/>	<input type="checkbox"/>			
C START STRINGS	<input type="checkbox"/>	<input type="checkbox"/>	PATTERN COUNT	<input type="checkbox"/>	<input type="checkbox"/>
			TIMEOUT COUNT	<input type="checkbox"/>	<input type="checkbox"/>
EXT. EIA STARTS	<input type="checkbox"/>				
EXT. EIA STOPS	<input type="checkbox"/>				

COUNTER CONFIGURATION PAGE

Figure 5. Counter Configuration Page

SECTION 3

9. TIMEOUT-STOP FUNCTION

9.01 Timeout-stop is similar to the start/stop function described in part 8. In this function a timeout value can be used as a stop trigger. The line configuration parameters must be defined before this function can be performed. To perform this operation proceed as follows:

- (a) Select the TIMEOUT-STOP start/stop function as described in paragraph 7.21.
- (b) Select the desired start/stop conditions as described in paragraph 8.01, steps (b) through (j).
- (c) To execute this function press RUN. Operation is identical to start/stop operation except the resume count operation is not applicable to the timeout trigger. Logging and display cease upon the occurrence of the timeout if not stopped previously by another stop trigger. Timeout is measured from the occurrence of the start trigger.

10. ELAPSED TIME FUNCTIONS

10.01 Elapsed time functions use the start/stop triggers to measure the time between the occurrence of two events. Two functions permit measurements in seconds or milliseconds up to a maximum of 65,535. The line configuration parameters must be defined before this function can be performed. To perform these functions proceed as follows:

- (a) Select the ELAPSED SEC or ELAPSED MSEC start/stop function as described in paragraph 7.21.
- (b) Select the desired start/stop conditions as described in paragraph 8.01, steps (b) through (i).
- (c) To execute this function press RUN. The time between the selected events is measured, logged into the capture buffer, and displayed on the screen. This process is repeated until the capture buffer is full; at which time the capture mode is entered.

10.02 The capture mode for the elapsed time functions is different from the capture mode in the monitor function. In this case the top two lines on the screen display the trigger count, elapsed time function (seconds or milliseconds), and the minimum, average, and maximum time values measured. The remainder of the screen displays the recorded time measurements. The scroll controls can be used to display the entire content of the capture buffer. The maximum times are displayed in bright-intensity, blinking video; minimum times in normal-intensity, blinking video; and average times in normal-intensity, reverse video. The remaining times are displayed in normal video.

11. ELAPSED CHARACTER FUNCTION

11.01 Elapsed character function is similar to the elapsed time functions. In this case, however, the number of characters between the start and stop triggers are counted and displayed. The maximum count is 65,535. The line configuration parameters must be defined before this function can be performed. To perform this function proceed as follows:

- (a) Select the ELAPSED CHAR start/stop function as described in paragraph 7.21.
- (b) Select the desired start/stop conditions as described in paragraph 8.01, steps (b) through (i).
- (c) To execute this function press RUN. The number of characters between the selected events is repeatedly counted and displayed until the capture buffer is full. Operation enters the capture mode.

11.02 The capture mode in the elapsed character function is similar to the elapsed time functions. The trigger count, function (elapsed count), and the minimum, average, and maximum character counts are displayed on the top two lines. The recorded counts are displayed on the top two lines. The recorded counts are displayed on the rest of the

screen; maximum values in bright intensity, blinking video; minimum values in normal-intensity, blinking video; and average values in normal-intensity reverse video. The remaining values are displayed in normal video.

12. TAPE OPERATION

12.01 The tape unit provides automatic real-time recording of the data logged by the data link monitor, for later retrieval and analysis. All the start/stop and repeat parameters selected on the start/stop configuration page are in effect, permitting recording of only the selected events or conditions required.

12.02 Six functions are provided for tape unit operation; directory display, replay, record 1, record 2, format and verify. Before use, new tapes must be formatted. In the record function, the data received and stored in the capture buffer is automatically recorded on the tape. The directory display function permits reading of the tape and listing of the name, type, track, and length of each file. In the replay function any file can be selected and replayed for display.

12.03 Format. To format a tape, proceed as follows:

- (a) From the line identification or capture mode, press PAGE to display the configuration page menu.

Note: If operation is in the run mode it will be necessary to enter the capture mode by pressing CAPTURE before the manual step mode can be entered.

- (b) Press *A* to display the tape configuration page. (See figure 6.)
- (c) Using the CURSOR keys position the blinking cursor in the reverse-video FUNCTION field.
- (d) Press STEP until FORMAT is displayed.

- (e) Insert the tape cartridge in the tape unit. The TAPE READY indicator lights.

- (f) Press TAPE to select the tape operation of the tape/cursor keys. The TAPE indicator lights.

- (g) Press RECORD to initiate the format function.

- (h) The FORMAT display flashes indicating the format function is in progress and the header blocks are recorded on both tracks of the tape.

- (i) After both tracks have been recorded the tape is repositioned to the beginning of track 1, and the verify function is performed. *automatically.*

12.04 Verify. To verify a formatted tape proceed as follows:

- (a) Repeat steps (a) through (c) of paragraph 12.03.

- (b) Press STEP until VERIFY is displayed.

- (c) Insert the tape cartridge in the tape unit. The TAPE READY indicator lights.

- (d) Press TAPE to select the tape operation of the tape/cursor keys. The TAPE indicator lights.

- (e) Press PLAYBACK to initiate the verify function.

- (f) The VERIFY display flashes indicating the verify function is in progress, and both tracks of the tape are read. Any errors detected are displayed in the lower left corner of the screen.

- (g) After both tracks have been read and verified the tape is repositioned to the beginning of track 1 and VERIFY stops flashing.

SECTION 3

12.05 Record 1. The manual record function is the default tape function. If a tape cartridge is loaded in the tape unit at the time the run mode is entered, the tape will be positioned for recording file 1. Recording can now be initiated by pressing the RECORD key. A flashing R in the upper right corner of the screen indicates that recording is in progress. Recording can be interrupted by pressing STOP. This process may be repeated as many times as desired within a file.

The file must be closed at the end of recording by pressing CAPTURE.

12.06 Additional files may be recorded in the manual mode as follows:

- (a) From the line identification or capture mode, press PAGE to display the configuration page menu.
- (b) Sequentially select each configuration page and ensure that all parameter selections are as required.

The screenshot shows a terminal window titled "TAPE CONFIGURATION PAGE". It is divided into two main sections: "RECORD PARAMETERS:" and "REPLAY PARAMETERS:". Each section has fields for "MODE", "FILE #", and "FILE NAME", with some fields containing graphical cursors. To the right is a "TAPE DIRECTORY" table with columns for "FILE #", "NAME", "TYPE", "TRACK", and "LENGTH", listing entries from 0001 to 0010.

RECORD PARAMETERS:		TAPE DIRECTORY				
MODE	FILE #	FILE #	NAME	TYPE	TRACK	LENGTH
		0001				
		0002				
		0003				
		0004				
		0005				
		0006				
REPLAY PARAMETERS:		0007				
		0008				
		0009				
		0010				

Figure 6. Tape Configuration Page

(c) Select the tape configuration page.

(d) Using the CURSOR keys position the blinking cursor in the reverse video FUNCTION field.

(e) Press STEP until RECORD 1 is displayed.

(f) Position the cursor in the reverse video RECORD PARAMETERS MODE field.

(g) Press STEP until the desired record mode--END OF TRACK, END OF TAPE, or CONTINUOUS--is displayed.

(h) Position the cursor in the reverse-video RECORD PARAMETERS FILE # field.

(i) Press clear to delete any existing entries and to open the selection. Any existing entries are cleared, and the HEX PAD indicator lights.

(j) Using the hexadecimal keys, enter the number of the file to be recorded.

(k) Position the cursor in the reverse-video RECORD PARAMETERS FILE NAME field.

(l) Press clear to delete any existing entries and to open the selection. Any existing entries are deleted, and the HEX PAD indicator lights.

(m) Using the hexadecimal keys, enter a six character name for the file to be recorded. Each character is entered as the two hexadecimal digit equivalent of the character in ASCII code.

(n) After the file name has been entered, press RUN to enter the run mode. The tape indicator will light, and the tape will be automatically positioned for recording the selected file.

(o) Recording can now be initiated and interrupted, and the file closed as described in paragraph 12.05.

12.07 Record 2. To perform the automatic record function, proceed as follows:

(a) From the line identification or capture mode, press PAGE to display the configuration page menu.

(b) Sequentially select each configuration page by pressing PAGE and ensure that all parameter selections are as required.

(c) Select the tape configuration page.

(d) Using the CURSOR keys position the blinking cursor in the reverse video FUNCTION field.

(e) Press STEP until RECORD 2 is displayed.

(f) Position the cursor in the reverse video RECORD PARAMETERS MODE field.

(g) Press STEP until the desired record mode--END OF TRACK, END OF TAPE, or CONTINUOUS--is displayed.

(h) Position the cursor in the reverse-video RECORD PARAMETERS FILE # field.

(i) Press clear to delete any existing entries and to open the selection. Any existing entries are cleared, and the HEX PAD indicator lights.

(j) Using the hexadecimal keys, enter the number of the file to be recorded.

(k) Position the cursor in the reverse-video RECORD PARAMETERS FILE NAME field.

SECTION 3

(l) Press clear to delete any existing entries and to open the selection. Any existing entries are deleted, and the HEX PAD indicator lights.

(m) Using the hexadecimal keys, enter a six character name for the file to be recorded. Each character is entered as the two hexadecimal digit equivalent of the character in ASCII code.

(n) After the file name has been entered, press TAPE to select the tape operation of the tape/cursor keys.

(o) Press RECORD to initiate the run mode and real-time recording. Data is displayed and recorded in accordance with the selected parameters. A flashing R in the upper right corner of the screen indicates that recording is in progress.

(p) Recording continues until the run mode is terminated as the result of a stop trigger, the end of track or end of tape is reached, or CAPTURE is pressed.

(q) Following the record function, operation returns to the capture mode.

12.08 Directory Display. To display the directory, proceed as follows:

(a) Repeat steps (a) through (c) of paragraph 12.03.

(b) Press STEP until DIRECTORY is displayed.

(c) Insert the tape cartridge in the tape unit. The TAPE READY indicator lights.

(d) Press TAPE to select the tape operation of the tape/cursor keys. The TAPE indicator lights.

(e) Press PLAYBACK to initiate the directory display function.

(f) The DIRECTORY display flashes indicating the directory function is in progress, and the monitor reads both tracks of the tape. Each file is listed, including number, name, type track and length, on the tape configuration page.

(g) If the list exceeds the ten file capacity of the first page, the additional pages can be displayed by pressing the SCROLL up key.

(h) To scroll back through the pages, press SCROLL down, or to return to the first page of the display press SCROLL HOME.

12.09 Replay. Two replay procedures can be used. A manual playback procedure permits direct replay of file one on the tape without the use of the tape configuration page. The second procedure permits selection and replay of any recorded file from the tape configuration page.

12.10 The manual playback procedure can only be performed from the capture mode. To replay file one from a tape using this procedure, proceed as follows:

(a) Insert the tape cartridge in the tape unit. The TAPE READY indicator lights.

(b) Press TAPE to select tape operation of the tape/cursor keys. The TAPE indicator lights.

(c) Press PLAYBACK to initiate the replay function. The tape is positioned to file one and the first two blocks of data are read and stored in the capture buffer. The content of two records is equal to the capacity of the capture buffer.

(d) The entire content of the capture buffer and additional blocks on the tape can be viewed through the use of the SCROLL keys. All the scroll functions operable in the capture buffer are also operable during tape

replay, including scroll up, scroll down, shift scroll, and step scroll. (Refer to paragraphs 6.04 through 6.06. Each block is read from the tape and displayed as required.

12.11 To replay a selected file from tape, proceed as follows:

(a) Perform the directory display function as directed in paragraph 12.08 and select the desired file.

(b) Position the cursor to the FUNCTION field.

(c) Press STEP until REPLAY is displayed.

(d) Position the cursor to the REPLAY PARAMETERS FILE # field.

(e) Press clear to delete any existing entries and to open the selection. Any existing entries are cleared, and the HEX PAD indicator lights.

(f) Using the hexadecimal keys enter the number of the file to be replayed.

(g) Press TAPE to select the tape operation of the tape/cursor keys. The tape indicator lights.

(h) Press PLAYBACK to initiate the replay function.

(i) The tape is positioned to the selected file and the first two blocks of data are read and stored in the capture buffer. The entire content of the capture buffer and additional blocks on the tape can be

viewed as described for in the manual playback procedure in paragraph 12.09.

13. SELF-TESTS

13.01 Start Self-Tests. The monitor performs a series of self-tests immediately following turn-on. These tests include a PROM CRCC test, a processor timer test, a processor RAM test, and an extension RAM test. Failure of any of these tests will result in display of the corresponding test error page with the error identified. A description of these error pages is provided in the 802A Maintenance Practice.

13.02 Upon successful completion of the start self-tests, operation automatically enters the line identification mode, and LINE IDENTIFICATION IN PROGRESS is displayed on the screen.

13.03 Self-Test Mode. The self-test mode can be entered from the line identification mode by pressing the CLEAR key. The line identification mode is entered automatically following turn-on or can be entered from the capture mode by pressing reset. It is suggested that the interface input be disconnected to prevent interface identification before CLEAR can be pressed.

13.04 Upon entering the self-test mode the self-test menu is displayed. (See figure 7.) The menu offers three self-tests, including video RAM test, write/read loop test, and keyboard/video display test, in addition to the four tests performed automatically following turn-on. The operation of these tests is provided in the 802A Maintenance Practice. To return to the line identification mode press RESET.

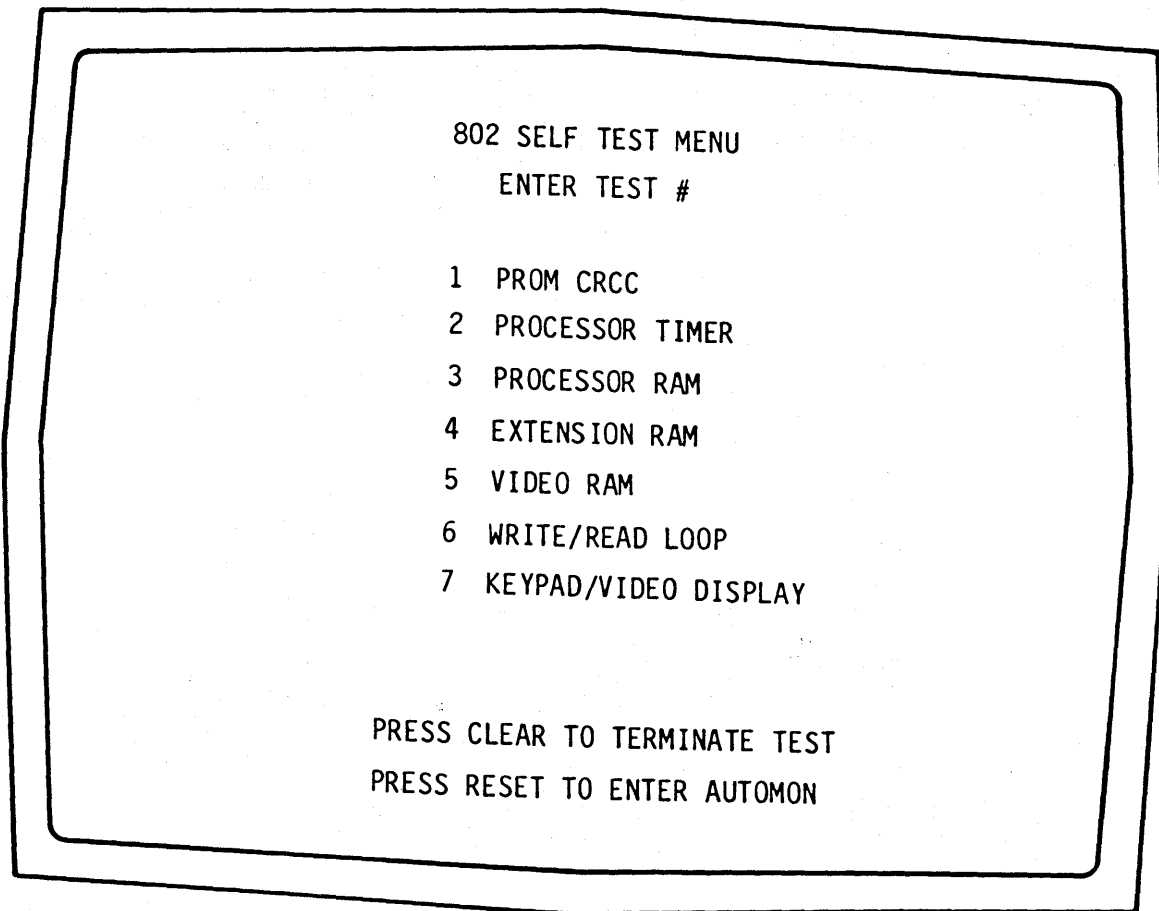

NOTE: ONLY TESTS 1-4 ARE EXECUTED DURING SELF-TEST

Figure 7. 802 Self-Test Menu

802A DATA LINK MONITOR

SECTION 4

OPERATION EXERCISES

CONTENTS	PAGE
1. GENERAL.....	1
2. AUTOMATIC DATA LINK MONITORING	1
3. MANUAL STEP OPERATIONS	4

Figures

1. Line/Display Configuration Page (Typical)	3
2. Start/Stop Configuration Page ..	4
3. Counter Configuration Page	5
4. Tape Configuration Page	7

1. GENERAL

1.01 This section contains exercises that aid the operator in familiarization with the 802A Data Link Monitor. Included is an exercise for monitoring a data link, if an active link is available, and exercises for performing parameter selections in the manual step mode.

2. AUTOMATIC DATA LINK MONITORING

A. Line Identification Mode

2.01 Monitoring a data link with the 802A couldn't be easier. If you have an active data link available, try it yourself as follows:

(a) Connect the power cord from the line connector on the rear of the monitor to the ac power source.

(b) Turn on the monitor by pressing the power switch.

(c) Connect the data link to the applicable interface connector on the rear of the monitor.

2.02 Operation starts in the line identification mode and the display indicates LINE IDENTIFICATION IN PROGRESS, PRESS PAGE FOR MANUAL STEP, CLEAR TO ENTER SELF-TEST. Normally, the monitor detects the line parameters and begins displaying the traffic in a few seconds. Operation has now entered the monitor function of the run mode.

B. The Run Mode

2.03 In the run mode an abbreviated display of the line configuration parameters is provided on the top two lines of the screen. The DTE parameters are displayed on the top line in normal video (white letters on a black background). The DCE parameters are displayed on the second line in reverse video (black on white). The received data is displayed on the remaining lines. DTE and DCE data are displayed on alternate lines with the DTE data starting at the left side of the third line and the DCE data directly below on the fourth line. Pad characters, periods when no data is being received on one or both sides of the line, are displayed as FF. As the last two lines of data are being written on the screen the data on the third and fourth lines are erased. New data is written on the blank lines and the next two lines are erased. This display mode is called line multiplex-pad.

2.04 While the monitor is in the run mode there are several operations available. This is a good opportunity to try some of them.

SECTION 4

- (a) Press the FREEZE/RESUME key. The data displayed on the screen freezes. This permits examination of a limited portion of the received data. The display format is the same as in the run mode.
- (b) Press FREEZE/RESUME a second time. The real-time data is again displayed.
- (c) Press the CODE/HEX key. The monitor continues logging and displaying the received data. All the characters are displayed in hexadecimal code, however.
- (d) Press CODE/HEX a second time, and characters are again displayed.
- (e) Press the MARK key. A blinking line is displayed under each received character as it is written on the screen.
- (f) Press MARK a second time. Subsequent characters are written without the underline. The underline remains on the characters previously written as long as they are on the screen.
- (g) Press the CAPTURE key. The capture mode is entered.

C. The Capture Mode

2.05 In the capture mode the display changes slightly. The received traffic is still displayed on the lower portion of the screen. The earliest received data remaining in the capture buffer is now displayed, starting on the third and fourth lines. A blinking cursor identifies the first displayed character from the DTE side of the line. This is the home position of the cursor. The top two lines on the screen no longer identify the line configuration parameters. The top line now displays the line number of the first displayed line of data (LINE #0001). The data bit pattern and any errors in the cursored character are identified on the second line.

2.06 Some of the operations applicable to the capture mode are performed as follows:

- (a) Momentarily press the CURSOR right key. The blinking cursor moves one character to the right, and the data bit pattern, displayed on the top line, changes to display the pattern of the new character.
- (b) Press and hold the CURSOR right key. The cursor moves across the screen to the right. As the cursor moves the bit pattern of each character is displayed. When the cursor reaches the right end of the first line it wraps around to left end of the second line.
- (c) Release the CURSOR right key. Cursor movement stops.
- (d) Momentarily press the CURSOR down key. The cursor moves down one line, and the bit pattern of the cursored character is displayed.
- (e) Press and hold the CURSOR down key. The cursor moves down one line at a time to the bottom of the screen. After reaching the bottom of the screen the cursor wraps around to the top of the data display, in the same column.
- (f) Repeat the above steps using the CURSOR left and up keys and observe the cursor movement.
- (g) Press the CURSOR HOME key. The CURSOR returns to the home position.
- (h) Momentarily press the SCROLL up key. The entire data display scrolls up two lines on the screen, and the line number, displayed on the top line, advances to two.
- (i) Press and hold the SCROLL up key. The display scrolls up on the screen and the line number advances two lines at a time. If you scroll long enough, the characters you marked

with the blinking underline in the run mode should be displayed.

(j) Release the SCROLL up key. Scrolling stops.

(k) Repeat the previous steps using SCROLL down and HOME keys and observe the scroll action.

(l) Press PAGE to display the configuration page menu.

(m) Press 1 to select the line/display configuration page. (See figure 1.) The line configuration parameters (detected in the line identification mode) can be examined on this page.

(n) Press PAGE a second time, then press 2 to select the start/stop configuration page. The start/stop configuration page is displayed with the default parameters. (See figure 2.)

LINE PARAMETERS		DISPLAY PARAMETERS	
PROTOCOL	SYNC	DISPLAY MODE	LINE MUX-PAD
	DTE DCE	DISPLAY SIZE	512-16X32
BIT RATE	FROM DCE	FROM DCE	
CODE/BITS	EBCDIC 78	EBCDIC 78	
PARITY	NONE	NONE	
CRCC POLY	CRC-16	CRC-16	
SYNC CHAR	3 2	3 2	
RESYNC	F	F	
DATA CHAN	PRIM	PRIM	
SENSE	NORM	NORM	
BIT ORDER	NORM	NORM	
ENCODING			
MONITOR PARAMETERS			
		MONITOR	DTE DCE
		MARK EXT IN	NONE
			DTE DCE
		SUPPRESS TEXT	NO NO
		SUPPRESS CHAR	
		PATTERN MATCH	

LINE/DISPLAY CONFIGURATION PAGE

Figure 1. Line/Display Configuration Page (Typical)

SECTION 4

(o) Press PAGE again, then press 3 to select the counter configuration page. The counter configuration page is displayed in the default condition, with all applicable counters disabled. (See figure 3.)

(p) Press PAGE again, then press 4 to select the tape configuration page. The tape configuration page is displayed with the default parameters.

(q) Press CAPTURE. The capture page is again displayed.

3. MANUAL STEP OPERATIONS

3.01 The manual step mode permits manual selection of the parameters on the line/display, start/stop, and count-

er configuration pages. The following procedures illustrate these selections.

A. Line/Display Configuration Page

3.02 The line/display configuration page permits selection of the parameters associated with the input data and with the display of that data. Parameters typical of those on this configuration page are selected as follows:

(a) From the line identification mode or the capture mode, press PAGE to display the configuration page menu.

(b) Press 1 to select the line/display configuration page. (See figure 1.) The blinking cursor is in the

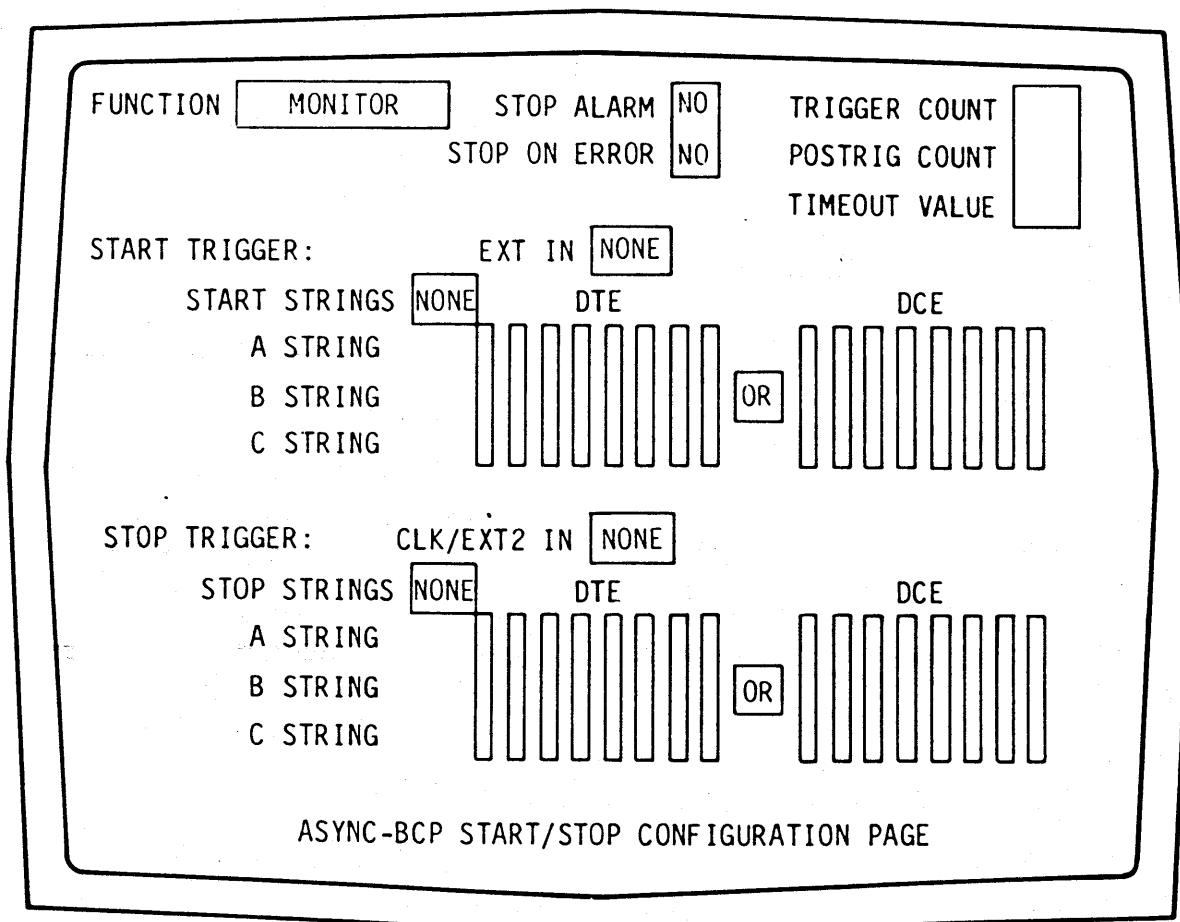

Figure 2. Start/Stop Configuration Page

PROTOCOL field. If the manual step mode was entered from the line identification mode, the default protocol, sync, is displayed. If entry was from the run mode, the detected protocol is displayed.

- (c) Press the STEP key. The next protocol is displayed.
- (d) Continue pressing the STEP key. The display steps through each available protocol.
- (e) Stop pressing when the original protocol is displayed.
- (f) Press each CURSOR key and observe the associated cursor movement.

(g) Position the cursor in the left CODE/BITS field under DTE. The default transmission code and bit per character values or the detected parameters are displayed.

(h) Press the STEP key. The next code and bit value are displayed for the DTE side. The DCE selection changes to agree with the DTE.

(i) Continue pressing the STEP key. The display steps through each code selection available. The corresponding bit per character values are displayed with each code. Stop pressing when the original code is displayed.

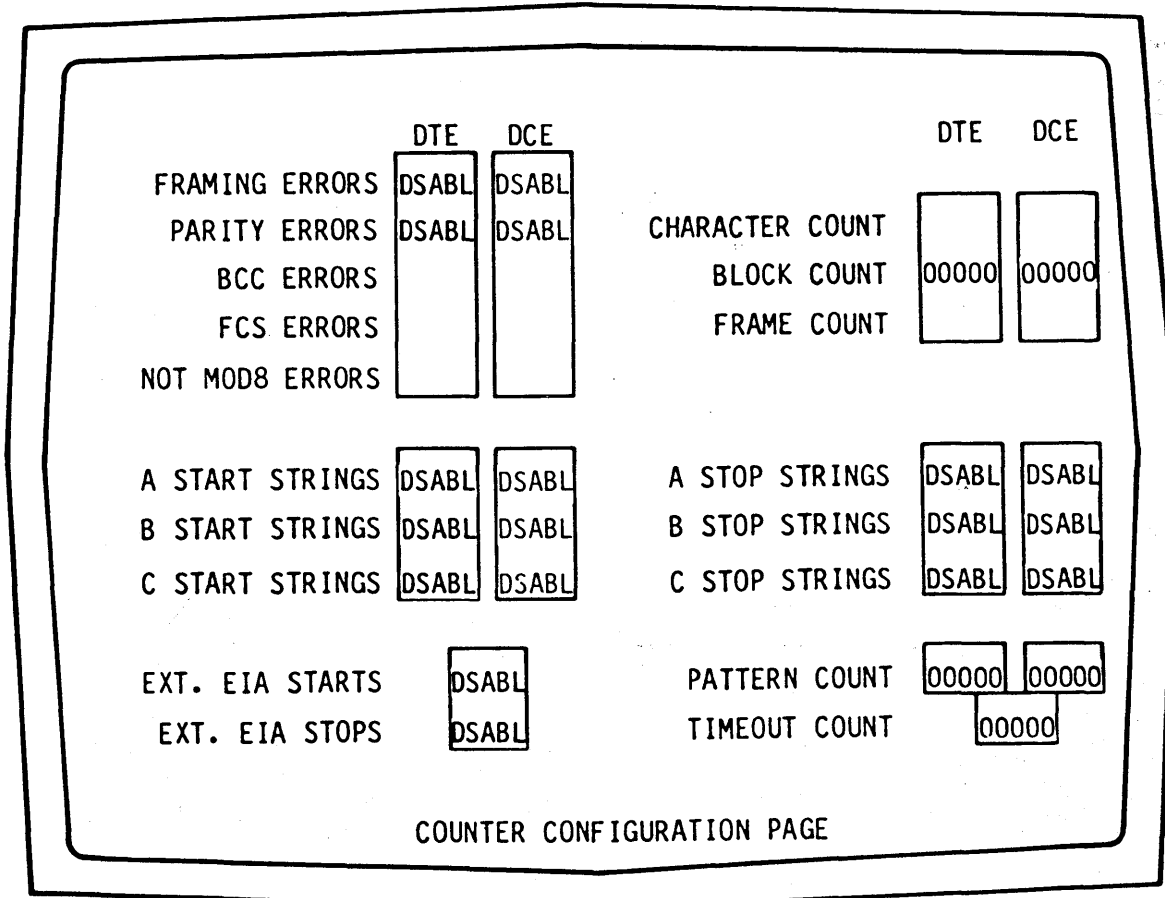

Figure 3. Counter Configuration Page

SECTION 4

(j) Position the cursor in the second CODE/BITS field under DTE. The current bits per character selection is displayed.

(k) Press STEP repeatedly to step through the bit per character selections of 5, 6, 7, and 8. The changes are performed for both DTE and DCE selections. Stop when the original value is displayed.

(l) Repeat steps (g) through (i) for the DCE selections and observe the results.

B. Start/Stop Configuration Page

3.03 The start/stop configuration page permits selection of the parameters that control the logging of data in the monitor. Parameters, typical of those on this page, are selected as follows:

(a) From the line/display configuration page, press PAGE to return to the configuration page menu, then press 2 to display the start/stop configuration page. (See figure 2.) The blinking cursor is in the FUNCTION field and MONITOR is displayed.

(b) Press STEP repeatedly to step through the function selections of TIMEOUT-STOP, ELAPSED SEC, ELAPSED MSEC, and ELAPSED CHAR. Stop when the display returns to MONITOR.

(c) Position the cursor in the first (left) dim-video, A STRING field.

(d) Press STEP. The display indicates ERROR 1 in the lower left corner.

(e) By looking in appendix B, you will see that error 1 indicates the key pressed initiated no action. The string entries must be opened by pressing CLEAR, then the entry mode.

(f) Press CLEAR. The error display is cleared, and the character string can be entered. The code to be used in entering the string depends on the

transmission code selected on the line/display configuration page.

(g) Using the hexadecimal keys, enter the two digit hexadecimal code for the first character you want to enter in the string. The hexadecimal codes can be determined by referring to appendix C. Random hexadecimal entries can be used for this exercise. Also, the DON'T CARE key can be used for a nondefinitive entry.

Note: To delete an erroneous character, press ENTER to terminate the selection, position the cursor over the character, and press CLEAR. The cursored character, and all subsequent entries in the string are deleted, and can be reentered.

(h) Continue entering the hexadecimal code for each character in the string.

(i) If less than a full eight character string is entered, the selection must be terminated by pressing ENTER.

(j) Delete the string by positioning the cursor over the first character in the string and pressing CLEAR.

(k) Terminate the selection by pressing ENTER.

NOTE: Attempting any action, except RESET, before terminating the selection will result in an error 10. Press ENTER to terminate the selection and clear the error.

C. Counter Configuration Page

3.04 The counter configuration page permits enabling any or all the counters associated with the selected protocol. Typical counter selection is performed as follows:

(a) From the start/stop configuration page, press PAGE to return to the configuration page menu, then press 3

to display the counter configuration page. (See figure 3.) Each applicable counter is identified by the word DSABL displayed in the reverse video field following the counter name. The blinking cursor is located in the DTE field of the first applicable counter on the left side of the screen.

- (b) Press STEP. The display indicates 00000, and the counter is enabled.
- (c) Press STEP again, and the display returns to DSABL, and the counter is disabled.
- (d) Position the cursor in another active counter field and repeat steps (b) and (c).

D. Tape Configuration Page

3.05 The tape configuration page permits selection of the tape functions and the record and replay mode

control parameters. Typical selections are performed as follows:

- (a) From the counter configuration page, press PAGE to return to the configuration page menu, then press ~~4~~ 5 to display the tape configuration page. (See figure 4.) The blinking cursor is located in the FUNCTION field.
- (b) Press STEP repeatedly to step through the tape functions.
- (c) Position the cursor in the RECORD PARAMETERS: MODE field.
- (d) Press STEP repeatedly and observe the record parameters.
- (e) Press PAGE to return to the capture page.
- (f) Press RESET to return to the line identification mode.

FUNCTION	<input type="text"/>	TAPE DIRECTORY
RECORD PARAMETERS:		FILE # NAME TYPE TRACK LENGTH
MODE	<input type="text"/>	0001
FILE #	<input type="text"/>	0002
FILE NAME	<input type="text"/>	0003
		0004
		0005
REPLAY PARAMETERS:		0006
MODE	<input type="text"/>	0007
FILE #	<input type="text"/>	0008
FILE NAME	<input type="text"/>	0009
		0010
ERROR		TAPE CONFIGURATION PAGE

Figure 4. Tape Configuration Page

**802A DATA LINK MONITOR
SECTION 5
APPLICATION NOTES**

CONTENTS	PAGE	CONTENTS	PAGE
1. GENERAL	1	7. SYNCHRONOUS RESPOND TO POLL	13
2. PRINTER OUTPUT	3	8. BIT ERROR RATE TESTING	15
3. MODEM OUTPUT	5	9. X.25 PROTOCOL ANALYSIS	17
4. ASYNCHRONOUS DATA TRANSMISSION	7	1 GENERAL	
5. SYNCHRONOUS POLL	9	1.01 This section contains applica- tion notes that describe specific uses of the 802A Data Link Analyzer.	
6. SYNCHRONOUS SELECT	11		

2. PRINTER OUTPUT

2.01 This application note describes the printer output capability of an 802A Data Link Monitor equipped with the Printer/Poll/BERT Option. This capability permits generation of a hard copy of the capture buffer data or the configuration pages on an asynchronous printer.

2.02 In this function the 802A operates as a DCE. The data output is asynchronous, ASCII seven-bit transmission code, with two stop bits. odd, even, and none parity selections are provided. Bit rates of 50, 75, 100, 110, 134.5, 150, 200, 300, 600, 1200, 1800, 2400, 4800, and 9600 bits per second are selectable. To perform the printout operation, proceed as follows:

(a) Using the receive cable, connect the RECEIVE connector on the interface adapter to the RECEIVE connector on the rear of the 802A.

(b) Using the transmit cable, connect the TRANSMIT connector on the interface adapter to the TRANSMIT connector on the rear of the 802A.

CAUTION: The TRANSMIT interface is NOT an RS-232-C interface and should not be connected directly to a data link.

(c) Press the MONITOR switch on the interface adapter.

(d) Connect the data source to the REC/XMT connector on the interface adapter.

(e) Monitor the data link and store the desired data in the capture buffer as described in Section 3 of this manual.

(f) Press CAPTURE to enter the capture mode.

(g) Disconnect the data source from the REC/XMT connector.

(h) Press the SIM DCE switch on the interface adapter.

(i) Connect the printer interface to the REC/XMT connector.

(j) Press PAGE to display the configuration page menu.

(k) Press key 4 to display the Printer/Poll/BERT page.

(l) With the blinking cursor in the reverse-video FUNCTION field, press STEP to step through the function selections until PRINTER is displayed.

(m) Position the cursor to the reverse-video BIT RATE field.

(n) Press STEP to step through the bit rate selections until the proper rate for the printer is displayed.

(o) Position the cursor in the PARITY field.

(p) Press STEP to select the desired parity parameter.

(q) Press PAGE to display the configuration page menu, then select the desired page for printout.

NOTE: When the capture buffer is selected, the printout will commence with the data displayed. Therefore, the SCROLL keys can be used to select the desired data in the capture buffer for printout.

(r) Press PRINT to initiate the print operation. The selected data will be transmitted to the printer.

(s) Printing will continue until the entire capture or display buffer has been transmitted or PRINT is pressed a second time.

SECTION 5

2.03 Each line in the printout is 32 characters long, the same length as a display line. Three lines are printed for each display line. The first line identifies the data attributes as follows:

- _ - DCE (Reverse-Video) Data
- N - No Data
- P - Parity Error
- F - Framing Error
- O - Overrun Error
- B - BCC Error
- C - Cursor

NOTE: Upper case letters are associated with DTE data, lower case letters with DCE data.

2.04 The second line in the printout contains the alphanumeric characters from the data and the first digit of any hexadecimal characters or the first character of any control-character abbreviations. The third line contains the second digit of any hexadecimal characters or the second character of any control-character abbreviations.

3. MODEM OUTPUT

3.01 This application note describes the modem output capability of an 802A Data Link Monitor equipped with the Printer/Poll/BERT Option. The printer output, described in Application Note 2, can also be transmitted through an asynchronous modem to a printer at a remote location.

3.02 In this function the 802A operates as a DTE. The data output is as described for the printer output. To perform this function, proceed as follows:

(a) Using the receive cable, connect the RECEIVE connector on the interface adapter to the RECEIVE connector on the rear of the 802A.

(b) Using the transmit cable, connect the TRANSMIT connector on the interface adapter to the TRANSMIT connector on the rear of the 802A.

CAUTION: The TRANSMIT interface is NOT an RS-232-C interface and should not be connected directly to a data link.

(c) Press the MONITOR switch on the interface adapter.

(d) Connect the data source to the REC/XMT connector on the interface adapter.

(e) Connect the modem to the MODEM connector on the interface adapter.

(f) Monitor the data link and store the desired data in the capture buffer as described in Section 3 of this manual.

(g) Press CAPTURE to enter the capture mode.

(h) Press the MODEM switch on the interface adapter.

(i) Establish communication through the modem to the remote location.

(j) Press PAGE to display the configuration page menu.

(k) Press key 4 to display the Printer/Poll/BERT page.

(l) With the blinking cursor in the reverse-video FUNCTION field, press STEP to step through the function selections, until PRINTER is displayed.

(m) Position the cursor to the reverse-video BIT RATE field.

(n) Press STEP to step through the bit-rate selections, until the proper rate for the modem is displayed.

(o) Position the cursor in the PARITY field.

(p) Press STEP to select the desired parity parameter.

(q) Press PAGE to display the desired page for printout.

NOTE: When the capture buffer is selected, the printout will commence with the data displayed. Therefore, the SCROLL keys can be used to select the desired data in the capture buffer for printout.

(r) Press PRINT to initiate the print operation. The selected data will be transmitted through the modem to the printer.

(s) Output will continue until the entire capture or display buffer has been transmitted or PRINT is pressed a second time.

3.03 The format of the printout will be as described in Application Note 2.

4. ASYNCHRONOUS DATA TRANSMISSION

4.01 This application note describes the asynchronous data transmission capability of an 802A Data Link Monitor equipped with the Printer/Poll/BERT Option. This function permits transmission of a predefined fox message or a user-defined message. The 802A can simulate either a DTE or a DCE in this function. The interface parameters for asynchronous transmission are selected on the configuration page. The protocol selection must be ASYNC and the code selection ASCII. The bit-rate, bits-per-character, and parity parameters are selectable. To perform a message transmission, proceed as follows:

(a) Using the receive cable, connect the RECEIVE connector on the interface adapter to the RECEIVE connector on the rear of the 802A.

(b) Using the transmit cable, connect the TRANSMIT connector on the interface adapter to the TRANSMIT connector on the rear of the 802A.

CAUTION: The TRANSMIT interface is NOT an RS-232-C interface and should not be connected directly to a data link.

(c) Press the SIM DTE or SIM DCE switch on the interface adapter to configure the 802A to simulate a DTE or DCE as required.

(d) Connect the data interface to the REC/XMT connector on the interface adapter.

(e) From the Automonitor mode press PAGE to display the configuration page menu.

(f) Press key 1 to display the Line/Display page.

(g) With the blinking cursor in the reverse-video PROTOCOL field, press STEP until ASYNC is displayed.

(h) Using the cursor and ENTER keys, select the bit-rate, bits-per-character, parity, and trigger count parameters as required.

(i) Press PAGE to display the configuration page menu.

(j) Press key 4 to display the Printer/Poll/BERT page.

(k) With the cursor in the FUNCTION field, press STEP to select the desired fox message or user-message function. If user message is selected enter the message, or messages, as described in steps (l) through (n). To transmit the fox message proceed to step (r).

(l) To enter a user message, position the cursor in first (left) character position of the reverse-video field below MESSAGE.

(m) Press CLEAR to clear any existing entries and to open the selection. Any existing entries are deleted and the HEX PAD indicator lights.

(n) Using the hexadecimal keys, enter the two-digit hexadecimal code for the first character of the message. The first character is displayed and the cursor moves to the right one space.

(o) Continue entering the hexadecimal codes for each character in the message. Up to 16 characters can be entered in a message.

(p) If fewer than 16 characters are required in the message, press ENTER to terminate the selection. Selection is automatically terminated following entry of the sixteenth character, in which case it is not necessary to press ENTER. Following termination of the message entry, the cursor will return to the FUNCTION field.

SECTION 5

(q) Additional messages can be entered by positioning the cursor in the reverse-video field following MESSAGE, pressing STEP to step to the next message selection, and repeating steps (j) through (n). Up to 15 messages can be entered in this manner.

(r) Any of the 15 messages can be selected for individual transmission, with a sixteenth selection

permitting transmission of all the messages sequentially.

(s) To initiate transmission, press SEND. Transmission will commence. The data page with the transmitted data will be displayed.

(t) Transmission will continue until the trigger count is complete, SEND is pressed a second time, or CAPTURE is pressed.

5. SYNCHRONOUS POLL

5.01 This application note describes the poll capability of an 802A Data Link Monitor equipped with the Printer/Poll/BERT option. This capability permits generation of a general or specific poll for testing the response capability of a synchronous device or controller, to a poll.

5.02 In this function the 802A can operate as either a DCE or a DTE. The data output is synchronous with either ASCII or EBCDIC transmission code. To perform the poll function, proceed as follows:

(a) Using the receive cable, connect the RECEIVE connector on the interface adapter to the RECEIVE connector on the rear of the 802A.

(b) Using the transmit cable, connect the TRANSMIT connector on the interface adapter to the TRANSMIT connector on the rear of the 802A.

CAUTION: The TRANSMIT interface is NOT an RS-232-C interface and should not be connected directly to a data link.

(c) Press the SIM DCE or SIM DTE switch on the interface adapter to conform with interface requirement.

(d) Connect the REC/XMT connector on the interface adapter to the unit to be tested or to the modem if testing is to be performed through the data link.

(e) Press PAGE to display the configuration page menu.

(f) Press key 1 to display the Line/Display page.

(g) With the cursor in the reverse video PROTOCOL field, press STEP to display SYNC.

(h) Using the CURSOR keys, position the cursor to the DTE BIT RATE field.

(i) If the 802A is simulating a DCE press STEP to select the desired bit rate. If the 802A is simulating a DTE the FROM DCE clock should be selected.

(j) Position the cursor to the reverse video CODE field and select the desired transmission code.

(k) Repeat step (k) for PARITY and CRCC selections.

NOTE: To perform the poll operation continuously proceed to step (o) to select a trigger count continue with step (l).

(l) Position the cursor to the reverse video TRIG field.

(m) Press CLEAR to delete any existing value and to open the selection. Any existing value is deleted, and the HEX PAD indicator lights.

(n) Using the hexadecimal keys enter the desired trigger count as a decimal value up to 9,999.

NOTE: If an erroneous key is pressed, press ENTER to terminate the selection and press CLEAR to delete the entry; then re-enter.

(o) Press PAGE to display the configuration page menu.

(p) Press key 4 to display the Printer/Poll/BERT page.

(q) With the cursor in the reverse video function field, press STEP to select POLL.

(r) Position the cursor to the reverse video SIM field and press ENTER to agree with the selection in step (c).

SECTION 5

(s) Position the cursor to the first (left) character position in the reverse video ADDRESS field and enter the polling address as described in steps (t) through (v).

(t) Press CLEAR to delete the existing address and to open the selection. The existing address is deleted, and the HEX PAD indicator lights.

(u) Using the hexadecimal keys, enter the desired address in hexadecimal.

(v) Following address entry press ENTER to terminate the selection.

(w) Press SEND to initiate the transmission. Operation will enter the

run mode and the poll message, as displayed, will be transmitted. The 802A will monitor for a response, consisting of either a terminate (EOT) or a message, from the unit under test. If a terminate is received, the poll message will be repeated. If a message is received, the 802A will acknowledge by transmitting an ACK1 and monitor for a terminate. If a valid response is not received within approximately three seconds the poll message will be retransmitted. The transmission sequence will be limited by the trigger count selected in step (n).

(x) The capture mode will be entered following completion of the trigger count or by pressing CAPTURE.

6. SYNCHRONOUS SELECT

6.01 This application note describes the select capability of an 802A Data Link Monitor equipped with the Printer/Poll/BERT option. This capability permits selection and transmission of a test message to a synchronous terminal or printer.

6.02 In this function the 802A can operate as either a DCE or a DTE. The data output is synchronous with either ASCII or EBCDIC transmission code. To perform the select function, proceed as follows:

(a) Using the receive cable, connect the RECEIVE connector on the interface adapter to the RECEIVE connector on the rear of the 802A.

(b) Using the transmit cable, connect the TRANSMIT connector on the interface adapter to the TRANSMIT connector on the rear of the 802A.

CAUTION: The TRANSMIT interface is NOT an RS-232-C interface and should not be connected directly to a data link.

(c) Press the SIM DCE or SIM DTE switch on the interface adapter to conform with interface requirement.

(d) Connect the REC/XMT connector on the interface adapter to the unit to be tested or to the modem if testing is to be performed through the data link.

(e) Press PAGE to display the configuration page menu.

(f) Press key 1 to display the Line/Display page.

(g) With the cursor in the reverse video PROTOCOL field, press STEP to display SYNC.

(h) Using the CURSOR keys, position

the cursor to the DTE BIT RATE field.

(i) If the 802A is simulating a DCE press STEP to select the desired bit rate. If the 802A is simulating a DTE the FROM DCE clock should be selected.

(j) Position the cursor to the reverse video CODE field and select the desired transmission code.

(k) Repeat step (l) for PARITY and CRCC selections.

NOTE: To perform the select operation continuously, proceed to step (o), to select a trigger count continue with step (l).

(l) Position the cursor to the reverse video TRIG field.

(m) Press CLEAR to delete any existing value and to open the selection. Any existing value is deleted, and the HEX PAD indicator lights.

(n) Using the hexadecimal keys enter the desired trigger count as a decimal value up to 9,999.

NOTE: If an erroneous key is pressed, press ENTER to terminate the selection and press CLEAR to delete the entry; then re-enter.

(o) Press PAGE to display the configuration page menu.

(p) Press key 4 to display the Printer/Poll/BERT page.

(q) With the cursor in the reverse video function field, press STEP to select SELECT.

(r) Position the cursor to the reverse video SIM field and press STEP to agree with the selection in step (c).

(s) Position the cursor to the first (left) character position in the

SECTION 5

reverse video ADDRESS field and enter the polling address as described in steps (t) through (x).

(t) Press CLEAR to delete the existing address and to open the selection.

The existing address is deleted, and the HEX PAD indicator lights.

(u) Using the hexadecimal keys, enter the desired address in hexadecimal.

(v) Following address entry press ENTER to terminate the selection.

(w) Press SEND to initiate the transmission. Operation will enter the

run mode and the select message, as displayed, will be transmitted. The 802A will monitor for an ACK 0 response. If an ACK 0 is not received the select message will be retransmitted. Following receipt of an ACK 0 the test message will be transmitted. At this time the 802A will monitor for an ACK 1. If an ACK 1 is not received the select message will be retransmitted. Following receipt of the ACK 1 a terminate (EOT) will be transmitted.

(x) The capture mode will be entered following completion of the trigger count or by pressing CAPTURE.

7. SYNCHRONOUS RESPOND TO POLL

7.01 This application note describes the respond-to-poll capability of an 802A Data Link Monitor equipped with the Printer/Poll/BERT option. This capability permits the 802A to simulate a synchronous device or controller in responding to a general or specific poll.

7.02 In this function the 802A can operate as either a DCE or a DTE. The data output is synchronous with either ASCII or EBCDIC transmission code. To perform the select-to-poll function, proceed as follows:

(a) Using the receive cable, connect the RECEIVE connector on the interface adapter to the RECEIVE connector on the rear of the 802A.

(b) Using the transmit cable, connect the TRANSMIT connector on the interface adapter to the TRANSMIT connector on the rear of the 802A.

CAUTION: The TRANSMIT interface is NOT an RS-232-C interface and should not be connected directly to a data link.

(c) Press the SIM DCE or SIM DTE switch on the interface adapter to conform with interface requirement.

(d) Connect the REC/XMT connector on the interface adapter to the unit to be tested or to the modem if testing is to be performed through the data link.

(e) Press PAGE to display the configuration page menu.

(f) Press key 1 to display the Line/Display page.

(g) With the cursor in the reverse video PROTOCOL field, press STEP to display SYNC.

(h) Using the CURSOR keys, position the cursor to the DTE BIT RATE field.

(i) If the 802A is simulating a DCE press STEP to select the desired bit rate. If the 802A is simulating a DTE the FROM DCE clock should be selected.

(j) Position the cursor to the reverse video CODE field and select the desired transmission code.

(k) Repeat step (j) for PARITY and CRCC selections.

NOTE: To perform the poll operation continuously proceed to step (o) To select a trigger count continue with step (l).

(l) Position the cursor to the reverse video TRIG field.

(m) Press CLEAR to delete any existing value and to open the selection. Any existing value is deleted, and the HEX PAD indicator lights.

(n) Using the hexadecimal keys enter the desired trigger count as a decimal value up to 9,999.

NOTE: If an erroneous key is pressed, press ENTER to terminate the selection and press CLEAR to delete the entry; then re-enter.

(o) Press PAGE to display the configuration page menu.

(p) Press key 4 to display the Printer/Poll/BERT page.

(q) With the cursor in the reverse video function field, press STEP to select RESPOND TO POLL.

(r) Position the cursor to the reverse video SIM field and press STEP to agree with the selection in step (c).

(s) Position the cursor to the first

SECTION 5

(left) character position in the reverse video ADDRESS field and enter the polling address as described in steps (t) through (v).

(t) Press CLEAR to delete the existing address and to open the selection. The existing address is deleted, and the HEX PAD indicator lights.

(u) Using the hexadecimal keys, enter the desired address in hexadecimal.

(v) Following address entry press ENTER to terminate the selection.

(w) Press SEND to initiate the transmission. Operation will enter the run mode and the 802A will monitor for the selected address. Upon receipt of the address the 802A will respond with a terminate (EOT).

(x) The capture mode will be entered following completion of the trigger count or by pressing CAPTURE.

8. BIT ERROR RATE TESTING

8.01 This application note describes the bit error rate testing (BERT) capability of an 802A Data Monitor equipped with the Printer/Poll/BERT Option. This capability permits testing of the transmission quality of both asynchronous and synchronous data links.

8.02 In this function the 802A operates as a DTE. The output can be either asynchronous or synchronous. Either 511 or 2047 bit patterns can be used. A transmit, receive, or loopback operation can be performed by the 802A. To perform BERT testing, proceed as follows:

(a) Using the receive cable, connect the RECEIVE connector on the interface adapter to the RECEIVE connector on the rear of the 802A.

(b) Using the transmit cable, connect the TRANSMIT connector on the interface adapter to the TRANSMIT connector on the rear of the 802A.

CAUTION: The TRANSMIT interface is NOT an RS-232-C interface and should not be connected directly to a data link.

(c) Press the SIM DTE switch on the interface adapter.

(d) Connect the REC/XMT connector on the interface adapter to the modem at the end of the data link being tested.

(e) Press PAGE to display the configuration page menu.

(f) Press key 1 to display the Line/Display page.

(g) With the cursor in the reverse video PROTOCOL field, press STEP to display ASYNC or SYNC as required.

(h) Using the CURSOR keys, position the cursor to the DTE BIT RATE field.

(i) If the 802A is operating in asynchronous, STEP to select the desired bit rate. If the 802A is operating in synchronous the FROM DCE clock should be selected.

NOTE: To perform the BERT operation continuously proceed to step (m). To select a trigger count continue with step (l).

(j) Position the cursor to the reverse video TRIG field.

(k) Press CLEAR to delete any existing value and to open the selection. Any existing value is deleted, and the HEX PAD indicator lights.

(l) Using the hexadecimal keys enter the desired trigger count as a decimal value up to 9,999.

NOTE: If an erroneous key is pressed, press ENTER to terminate the selection and press CLEAR to delete the entry; then re-enter.

(m) Press PAGE to display the configuration page menu.

(n) Press key 4 to display the Printer/Poll/BERT page.

(o) With the cursor in the reverse video function field, press STEP to select BERT.

(p) Position the cursor to the reverse video operation field and press STEP to select TRANSMIT, RECEIVE, or LOOPBACK as required.

(q) If transmit or receive is selected, an 802A or comparable BERT tester will be required at the other end of the data link to perform the test. If loopback is selected, a loopback must be performed somewhere in the data link.

(r) Position the cursor to the reverse video PATTERN field and select the 511 or 2047 pattern as desired.

SECTION 5

(s) Pressing SEND will initiate the test. The test will continue until the trigger count is complete or CAPTURE is pressed. At this time the number of blocks transmitted, number of blocks received, number of blocks

containing errors, and the total number of bits in error are displayed. Any blocks received that contain more than 20 errors are discarded and not counted as being received.

9. X.25 PROTOCOL ANALYSIS

9.01 This application note provides user support for 802A Data Link Monitors equipped with the X.25 Protocol Monitoring Option. X.25 is the number assigned to the CCITT recommendation Interface Between Data Terminal Equipment (DTE) and Data Circuit-Terminating Equipment (DCE) for Terminals Operating in the Packet Mode on Public Data Networks. This recommendation defines the physical level (level 1), frame level (level 2), and packet level (level 3) of the interface. The X.25 option permits analysis of both the frame and packet level fields of X.25 frames by the 802A.

A. Physical Level

9.02 The physical level of the interface includes the mechanical, electrical, functional, and procedural characteristics that activate, maintain, and deactivate the physical link between the packet DTE and public data network (PDN) DCE. The X.25 recommendation specifies X.21 or X.21 bis for this level; however, RS-232C is most commonly used in the United States at this time.

B. Frame Level

9.03 The frame level of the interface provides the procedures for establishing, maintaining, and terminating access to the link between the DTE and the DCE. Two link access procedures are defined by the X.25 recommendations: link access procedure (LAP) and link access procedure B (LAPB). Link access procedure B is currently in common use and is preferred for new implementations. The X.25 recommendation calls for high-level data link control (HDLC) transmission; however, binary synchronous communications (BSC or bisync) is also used. Frame formats for each type of transmission are shown in figure 9-1.

9.04 The frame-level fields include the address, control, and frame-check-sequence (FCS) or block-check-character

(BCC) fields. These fields provide control and management of the data link and, where applicable, provide the communications path for the packet-level fields. In HDLC framing, each frame is preceded and followed by at least one flag. The flags are eight-bit bytes that have the bit pattern 01111110 (7E) and identify the opening and closing of the frame.

9.05 Address Field. The address field is an eight-bit byte that consists of either an address A or address B. Address A has the bit pattern 00000011 (03). Address B has the bit pattern 00000001 (01). The address functions are as follows:

- (a) Frames containing commands transferred from the DCE to the DTE contain address A.
- (b) Frames containing responses transferred from the DTE to the DCE contain address A.
- (c) Frames containing commands transferred from the DTE to the DCE contain address B.
- (d) Frames containing responses transferred from the DCE to the DTE contain address B.

9.06 Control Field. The control field is an eight-bit byte that identifies the function performed by the frame. Three types of control functions are provided: numbered supervisory functions (S frames); unnumbered control functions (U frames); and numbered information transfers (I frames). Supervisory frames perform link supervisory control. Unnumbered frames provide link setup and disconnect control. Information frames provide packet-level data and control transfers. A list of the functions and the corresponding codes is provided in table 9-1.

9.07 Each I frame sent across the link is identified by a three-bit transmitter sequence count (Ns) in the

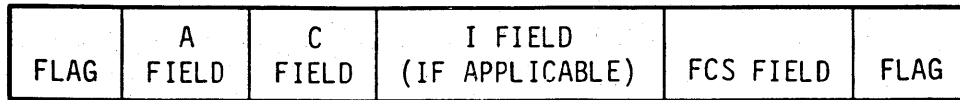

HDLC FRAMING

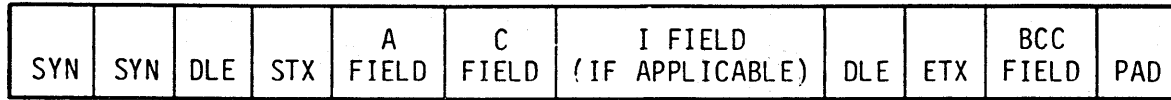

BSC FRAMING

Figure 9-1. X.25 Frame Formats

control field of the I frame. Received I frames are acknowledged by a three-bit receiver sequence count (Nr) in the control field of the responding I or S frame. Up to seven I frames can be outstanding before acknowledgement. All outstanding I frames, up to and including the last one received, are acknowledged by an Nr equal to the next expected Ns.

9.08 Receive Ready (RR) Command/Response. A receive-ready command is issued by the DTE or DCE to indicate it is ready to receive an I frame or, by setting the poll bit, to initiate a request for status. A receive-ready response is issued by the DTE or DCE to acknowledge previously received information frames, respond to an information frame that had the poll bit set, or to clear a busy condition that was initiated by the transmission of an RNR response. I frames numbered up to and including Nr-1 are acknowledged by an Nr equal to the next expected Ns.

9.09 Receive Not Ready (RNR) Command/Response. A receive-not-ready response is issued by the DTE or DCE to indicate a busy condition; i.e., a temporary inability to accept additional incoming I frames. I frames numbered up to and including Nr-1 are acknowledged by an Nr equal to the next expected Ns. Any subsequent frames are not acknowledged. A receive-not-ready command with the poll bit set initiates a request for status.

9.10 Reject (REJ) Command/Response. A reject response is issued by the DTE or DCE to request retransmission of I frames starting with frame numbered Nr. Frames up to and including Nr-1 are acknowledged. A reject with the poll bit set initiates a request for status.

9.11 Set Asynchronous Response Mode (SARM) Command. This command is associated with LAP and is issued to initiate the asynchronous response mode (ARM). Previously transmitted I frames that are unacknowledged when this command is issued remain unacknowledged. The response to a SARM command is an unnumbered-acknowledge response.

9.12 Disconnected Mode (DM) Response. This command is associated with LAPB and is issued by the DCE, in response to a disconnect command or any other command with the poll bit set to 1, to indicate the disconnected status of the DCE.

9.13 Set Asynchronous Balanced Mode (SABM) Command. This command is associated with LAPB and is issued to place the addressed DTE or DCE in the asynchronous balanced mode (ABM). Previously transmitted I frames that are unacknowledged when this command is issued remain unacknowledged. The response to a SABM command is an unnumbered-acknowledge response.

TABLE 9-1. Control Field Formats

FUNCTION	BIT PATTERN (MSB First)	HEXADECIMAL	
		P/F=1	P/F=0
SUPERVISORY			
Receive Ready (RR) Command/Response	Nr P/F 0001	-1	-1
Receive Not Ready (RNR) Command/Response	Nr P/F 0101	-5	-5
Reject (REJ) Command/Response	Nr P/F 1001	-9	-9
UNNUMBERED			
Set Asynchronous Response Mode (SARM) Command	000 P 1111	1F	0F
Set Asynchronous Balanced Mode (SABM) Command	001 P 1111	3F	2F
Disconnect (DISC) Command	010 P 0011	53	43
Unnumbered Acknowledge (UA) Response	011 F 0011	73	63
Disconnected Mode (DM) Response	000 F 1111	1F	0F
Command Reject (CMDR) Response	100 F 0111	97	87
Frame Reject (FRMR) Response	100 F 0111	97	87
INFORMATION			
Information (I) Command	Nr P Ns 0	—	—

Where: P = Poll bit requesting transmission from secondary station.
 F = Final bit indicates end-of-transmission from secondary station.
 Nr = Receiver sequence count.
 Ns = Transmitter sequence count.

SECTION 5

9.14 Disconnect (DISC) Command. A disconnect command is issued by the DTE or DCE to indicate it is suspending operation. Acceptance of a DISC command is confirmed by an unnumbered-acknowledge response. Upon receipt of the confirmation the issuing DTE or DCE enters the disconnect phase. Previously transmitted I frames that are unacknowledged when this command is issued remain unacknowledged.

9.15 Unnumbered Acknowledge (UA) Response. An unnumbered-acknowledge response is issued by the DTE or DCE to confirm receipt and acceptance of a SABM or DISC command. The command is not actioned until the UA response is transmitted.

9.16 Disconnected Mode (DM) Response. The disconnected-mode response is issued by the DTE in response to a SABM command, or to any other command received that has the poll bit set to 1, to inform the DCE that it is logically disconnected from the link.

9.17 Frame Reject (FRMR) Response. A frame-reject response is issued by the DTE or DCE to report an error condition not recoverable by retransmission of the identical frame. Except for the information frames, the frame-reject response (FRMR) is the only frame that has an information field. The format of this field is shown in figure 9-2.

9.18 Information (I) Command. Information commands are issued by the DTE or DCE to transfer sequentially numbered frames, each containing an information field. The content and format of the information fields is described under the packet level section below.

9.19 Frame Check Sequence Field. The frame-check-sequence field follows the control field in supervisory and unnumbered frames or follows the information-transfer field in information frames. This field is 16 bits in length and contains the result of a cyclic re-

dundancy check (CRC) performed on the data in the frame.

C. Packet Level

9.20 The packet level of the interface provides the procedures for establishing, maintaining, and terminating a virtual call through the network from the local DTE to a remote DTE. These procedures provide for the exchange of control information and user data contained in the information-transfer fields of the information frames. Only one packet is contained in an information-transfer field and only one information-transfer field is contained in an information frame. The format of the header of a typical packet is shown in figure 9-3.

9.21 The general format identifier (GFI) is a four-bit field that identifies the general format of the rest of the packet. This field consists of bits 8 through 5 of the first octet in the packet.

(a) Bit 8 is the qualifier (Q) bit.

The Q bit for user-data transfers is set to 0. The 1 state of this bit is reserved for data packets containing control information as described in CCITT recommendation X.29.

(b) Bit 7 is the delivery-confirmation (D) bit. This bit is used to

request end-to-end acknowledgement of a data packet. The D bit is set to 1 in the call request packet by the calling DTE to the DCE, and in the incoming call packet to the called DTE, to indicate that end-to-end acknowledgement of data packets may be employed during the call. The called DTE can also implement the D bit in the call-accepted and call-connected packets in a similar manner. A data packet with the D bit set to 1 requests end-to-end acknowledgement of that packet.

	BIT ORDER								
OCTET	8	7	6	5	4	3	2	1	
1	X	X	X	X	X	X	X	X	- Rejected Frame Control Field
2	Nr	R	Ns	0					- State Variable Field
3	0	0	0	0	Z	Y	X	W	- Cause Code Field

1. The Rejected Frame Control Field is the control field of the received frame that initiated the FRMR.
2. The State Variable Field has the following format:

Nr R Ns 0

Where: Nr = The three bit current receive-sequence number.
 Ns = The three bit current send-sequence number.
 R = Set to 0 if the rejected frame was a command or to 1 if a response.

3. The Cause Code Field has the following format:

0000ZYXW

Where: W = Set to 1 if the control field of the rejected frame was invalid.
 X = Set to 1 if the control field of the rejected frame was considered invalid because the frame contained an information field that was not permitted with the command. Bit W must also be set to 1 with this bit.
 Y = Set to 1 if an information frame and the information field exceeded the capacity of the rejecting station. This bit is mutually exclusive with bit W.
 Z = Set to 1 if the control field of the rejected frame contained an invalid Nr. This bit is mutually exclusive with bit W.

Figure 9-2. FRMR I-Field Format

BIT ORDER	
OCTET	8 7 6 5 4 3 2 1
1	Q D O 1 X X X X - GFI and LCGN
2	X X X X X X X X - LCN
3	X X X X X X X X - Packet-Type Identifier

Where: GFI = General Format Identifier
 LCGN = Logical Channel Group Number
 LCN = Logical Channel Number

Figure 9-3. Typical Packet Header Format

(c) Bits 6 and 5 indicate the format of the data in the data packet. The bit assignments are as follows:

- 00 - Unassigned
- 01 - Modulo 8 Numbering Sequence
- 10 - Modulo 128 Numbering Sequence
- 11 - GFI Extension

9.22 The logical-channel group number (LCGN) is a four-bit field that identifies the logical-channel group assigned to the virtual circuit on the DTE/DCE interface. This field consists of bits 4 through 1 of the first octet in the packet.

9.23 The logical-channel number (LCN) is an eight-bit byte that identifies the logical channel on the DTE/DCE interface. The LCGN and LCN provide numbering for up to 4095 simultaneous virtual calls on the interface. These numbers are assigned by the DTE on outgoing calls and by the DCE on incoming calls.

9.24 The packet-type identifier is an eight-bit byte that identifies the type of function performed by the packet. A list of the functions and the corresponding codes is provided in table 9-2.

9.25 Each data packet sent through the virtual circuit is identified by a three-bit packet send-sequence number

(Ps) in the packet-type identifier of the data packet. Received data packets are acknowledged by a three-bit receive-sequence number (Pr) in the packet-type identifier of the responding data or flow-control packet. Up to seven data packets can be outstanding before acknowledgement. All outstanding data packets, up to and including the last one received, are acknowledged by a Pr equal to the next expected Ps.

9.26 Call Request and Incoming Call. The call-request packet is initiated by the calling DTE and is transmitted over the local DTE/DCE interface to the network. At the called DTE the corresponding incoming call packet is received from the network over the remote DTE/DCE interface. The format of these packets is shown in figure 9-4. In addition to the packet header, previously described, these packets include address, facilities, and user data sections.

9.27 The address section is of variable length and contains field length indicators for the calling and called DTE addresses and includes the respective addresses.

9.28 The facilities section is up to 64 octets in length and contains a field length indicator and, when present, includes the optional facilities fields.

Table 9-2. Packet-Type ID Codes

PACKET TYPE		BIT PATTERN	HEX
From DTE to DCE	From DCE to DTE		
Call Set-Up and Clearing			
Call Request	Incoming Call	00001011	0B
Call Accepted	Call Connected	00001111	0F
Clear Request	Clear Indication	00010011	13
DTE Clear Confirmation	DCE Clear Confirmation	00010111	17
Data and Interrupt			
DTE Data	DCE Data	Pr MPs 0	—
DTE Interrupt	DCE Interrupt	00100011	23
DTE Interrupt Confirmation	DCE Interrupt Confirmation	00100111	27
Flow Control and Reset			
DTE RR	DCE RR	Pr 00001	-1
DTE RNR	DCE RNR	Pr 00101	-5
DTE REJ		Pr 01001	-9
Reset Request	Reset Indication	00011011	1B
DTE Reset Confirmation	DCE Reset Confirmation	00011111	1F
Restart			
Restart Request	Restart Indication	11111011	FB
DTE Restart Confirmation	DCE Restart Confirmation	11111111	FF
Diagnostic			
DTE Diagnostic	DCE Diagnostic	11110001	F1

Where: Pr = Packet receive-sequence number
 Ps = Packet send-sequence number
 M = More-data indicator

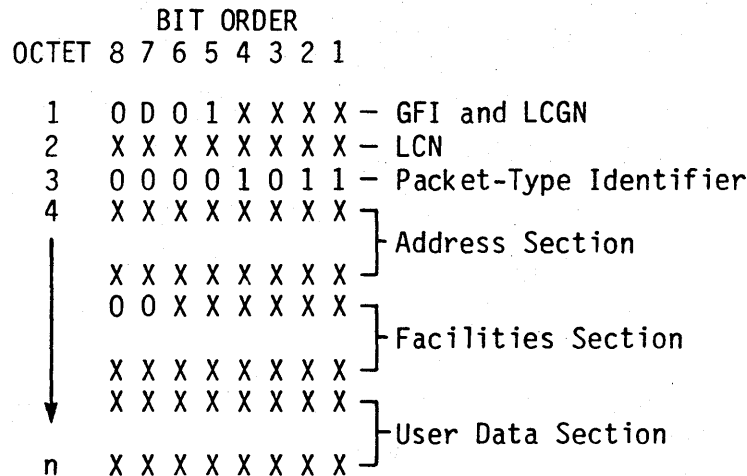

Figure 9-4. Call Request and Incoming Call Packet Format

9.29 The user data section, of up to 16 octets in length, is passed unchanged to the called DTE.

9.30 Call Accepted and Call Connected. The called DTE accepts an incoming call by transmitting a call-accepted packet over the remote DTE/DCE interface to the network. At the calling DTE, the corresponding call-connected packet is received from the network over the local DTE/DCE interface. The format of these packets is similar to that of the call-request and incoming-call packets described in paragraph 9.26. The address and facilities sections in these packets are optional. A user data section is not provided.

9.31 Clear Request and Clear Indication. The called DTE can refuse an incoming call by transmitting a clear request over the remote DTE/DCE interface to the network. At the calling DTE the corresponding clear-indication packet is received from the network over the local DTE/DCE interface. The format of these packets is shown in figure 9-5. These packets include a clearing cause as the fourth octet. A list of the clearing cause codes is provided in table 9-3. The clear-request packet,

initiated by the called DTE, contains a clearing cause having the bit pattern 00000000 (00). Clearing causes for the clear-indication packets are issued by the network. A diagnostic code, included as the fifth octet, is optional in the clear-request packet. A list of the diagnostic codes is provided in table 9-4. Additional octets in these packets are optional.

9.32 DTE and DCE Clear Confirmations. The calling DTE acknowledges receipt of a clear-indication packet by transmitting a DTE clear-confirmation packet over the local DTE/DCE interface to the network. The corresponding DCE clear-confirmation packet is received from the network over the remote DTE/DCE interface. DCE clear confirmations can also be originated by the network. The format of these packets is similar to that of the call-request and incoming-call packets described in paragraph 9.26. The address, facilities, and user-data sections of these packets are optional.

9.33 DTE and DCE Data. Once the call has been established the data transfer phase is entered and the calling DTE can begin transmitting DTE

BIT ORDER
OCTET 8 7 6 5 4 3 2 1

1	0 0 0 1 X X X X	- GFI and LCGN
2	X X X X X X X X	- LCN
3	0 0 0 1 0 0 1 1	- Packet-Type Identifier
4	X X X X X X X X	- Clearing Cause
5	X X X X X X X X	- Diagnostic Code

Figure 9-5. Clear Request and Clear Indication Packet Format

Table 9-3. Clearing Cause Codes

MESSAGE	BIT PATTERN	HEX
DTE Clearing	00000000	00
Number Busy	00000001	01
Invalid Facility Request	00000011	03
Network Congestion	00000101	05
Out of Order	00001001	09
Access Barred	00001011	0B
Not Obtainable	00001101	0D
Remote Procedure Error	00010001	11
Local Procedure Error	00010011	13
RPOA Out of Order	00010101	15
Reverse Charging Acceptance Not Subscribed	00011001	19
Incompatible Destination	00100001	21
Fast Select Acceptance Not Subscribed	00101001	29

Table 9-4. Diagnostic Codes

MESSAGE	BIT PATTERN	HEX
No Additional Information	00000000	00
Invalid Ps	00000001	01
Invalid Pr	00000010	02
Packet Type Invalid	00010000	10
For State r1	00010001	11
For State r2	00010010	12
For State r3	00010011	13
For State p1	00010100	14
For State p2	00010101	15
For State p3	00010110	16
For State p4	00010111	17
For State p5	00011000	18
For State p6	00011001	19
For State p7	00011010	1A
For State d1	00011011	1B
For State d2	00011100	1C
For State d3	00011101	1D
Packet Not Allowed	00100000	20
Unidentifiable Packet	00100001	21
Call On One Way Logical Channel	00100010	22
Invalid Packet Type On Permanent Virtual Circuit	00100011	23
Packet On Unassigned Logical Channel	00100100	24
REJECT Not Subscribed To	00100101	25

Table 9-4 Diagnostic Codes (Cont)

MESSAGE	BIT PATTERN	HEX
Packet Too Short	00100110	26
Packet Too Long	00100111	27
Invalid General Format Identifier	00101000	28
RESTART With Nonzero In Bits 1-4, 9-16	00101001	29
Packet Type Not Compatible With Facility	00101010	2A
Unauthorized Interrupt Confirmation	00101011	2B
Unauthorized Interrupt	00101100	2C
Timer Expired	00110000	30
For INCOMING CALL	00110001	31
For CLEAR INDICATION	00110010	32
For RESET INDICATION	00110011	33
For RESTART INDICATION	00110100	34
Call Setup Problem	01000000	40
Facility Code Not Allowed	01000001	41
Facility Parameter Not Allowed	01000010	42
Invalid Called Address	01000011	43
Invalid Calling Address	01000100	44

SECTION 5

data packets over the DTE/DCE interface to the network. At the called DTE, the corresponding DCE data packet is received from the network over the remote DTE/DCE interface. The format of these packets is shown in figure 9-6.

9.34 A data-qualifier (Q bit) and delivery-confirmation bit (D bit) are included in the general format identifier of data packets.

9.35 The packet-type identifier for the data packets is uniquely identified by a 0 as the least significant bit. In addition, this identifier includes a packet receive-sequence number (Pr), a more-data indicator (M), and a packet send-sequence number (Ps).

9.36 The packet receive-sequence number is a three-bit byte that is issued by the called DTE to indicate the anticipated packet send-sequence number of the next data packet to be received. This byte is used to acknowledge receipt of all data packets up to, but not including, that number.

9.37 The more-data indicator is a single bit that is issued by the calling DTE to indicate that the data in this packet will be continued in the next data packet to be transmitted. A 0 bit indicates the current message is completed in this packet.

9.38 The packet send-sequence number is a three-bit byte that is issued by the calling DTE to identify the current data packet.

9.39 DTE and DCE Interrupt. An interrupt provides the means of bypassing the normal data packet transmission sequence. The calling DTE initiates a DTE interrupt packet, which is transmitted over the local DTE/DCE interface to the network. At the called DTE the corresponding DCE interrupt packet is received from the network over the remote DTE/DCE interface. The format of these packets is shown in figure 9-7. The interrupt user-data field is limited to one octet.

9.40 DTE and DCE Interrupt Confirmation. The called DTE acknowledges receipt of a DCE interrupt packet by transmitting a DTE interrupt-confirmation packet over the remote DTE/DCE interface to the network. At the calling DTE, the corresponding DCE interrupt confirmation is received from the network over the local DTE/DCE interface. The format of these packets is shown in figure 9-8.

9.41 DTE and DCE Receive Ready. Both DTEs on a virtual circuit must periodically transmit a packet to maintain the circuit. If there is no data available for transmission at one end of

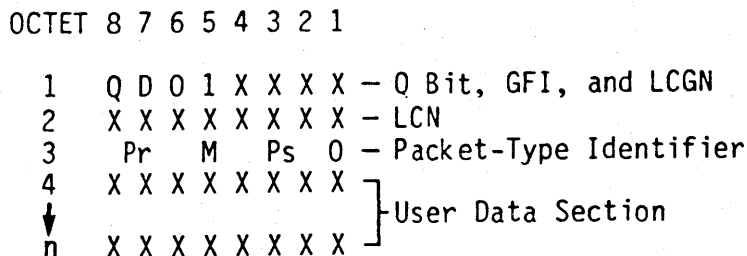

Figure 9-6. DTE and DCE Data Packet Format

```

          BIT ORDER
OCTET 8 7 6 5 4 3 2 1

1  0 0 0 1 X X X X - GFI and LCGN
2  X X X X X X X X - LCN
3  0 0 1 0 0 0 1 1 - Packet-Type Identifier
4  X X X X X X X X - Interrupt User Data

```

Figure 9-7. DTE and DCE Interrupt Packet Format

```

          BIT ORDER
OCTET 8 7 6 5 4 3 2 1

1  0 0 0 1 X X X X - GFI and LCGN
2  X X X X X X X X - LCN
3  0 0 1 0 0 1 1 1 - Packet-Type Identifier

```

Figure 9-8. DTE and DCE Interrupt Confirmation Packet Format

the circuit, a DTE receive-ready (RR) packet is initiated by the applicable DTE and transmitted over the DTE/DCE interface to the network. At the other end of the circuit, the DTE receives the corresponding DCE RR packet from the network over the DTE/DCE interface. The format of these packets is shown in figure 9-9. If the DTE initiating the receive ready has outstanding data packets that require acknowledgement, the required packet receive-sequence number (Pr) will be included in this packet.

9.42 DTE and DTE Receive not Ready. If either DTE on a virtual circuit is temporarily unable to receive additional data packets, that DTE can initiate and transmit over the DTE/DCE interface to the network a receive-not-ready (RNR) packet. At the other end of the circuit, the DTE receives the corresponding DCE RNR packet from the network over the DTE/DCE interface. The format of these

packets is similar to that of the DTE and DCE RR packets shown in figure 9-9. Receipt of data packets is acknowledged by the inclusion of the packet receive-sequence number (Pr) in these packets.

9.43 DTE Reject. Either DTE on a virtual circuit can request retransmission of one or more consecutive-data packets from the network by initiating and transmitting a DTE reject (REJ) over the DTE/DCE interface. The format of this packet is similar to that of the DTE and DCE RR packets shown in figure 9-9. This packet requests retransmission of all data packets starting with the one identified by the packet receive-sequence number (Pr) included in this packet.

9.44 Reset Request and Reset Indication. Either DTE on a virtual circuit can initiate a reset procedure by generating and transmitting a reset-request packet over the DTE/DCE inter-

BIT ORDER	
OCTET	8 7 6 5 4 3 2 1
1	0 0 0 1 X X X X - GFI and LCGN
2	X X X X X X X X - LCN
3	Pr 0 0 0 0 1 - Packet-Type Identifier

Figure 9-9. DTE and DCE Receive Ready Packet Format

face to the network. A reset reinitializes the virtual-call circuit. At the other end of the circuit, the DTE receives the corresponding reset indication from the network over the DTE/DCE interface. The format of these packets is shown in figure 9-10. The resetting-cause code is included as the fourth octet. A list of the codes is provided in table 9-5. The packet from the DTE issuing the request contains a resetting-cause code having the bit pattern 00000000 (00). Resetting-cause codes for the reset-indication packets are issued by the network. The optional diagnostic code may be included as the fifth octet. If included in the reset-request packet, this octet will be passed through the network to the reset-indication packet. A list of the diagnostic codes is provided in table 9-4.

9.45 DTE and DCE Reset Confirmation.

The DTE receiving a reset-indication packet acknowledges receipt by initiating and transmitting a DTE reset confirmation over the DTE/DCE interface to the network. At the other end of the circuit, the DTE receives the corresponding DCE reset-confirmation packet from the network over the DTE/DCE interface. The format of these packets is similar to the DTE and DCE interrupt-confirmation packets shown in figure 9-8.

9.46 Restart Request and Restart Indication.

Either DTE on a virtual circuit or the network can initiate a restart procedure by generating and

transmitting a restart-request packet over the DTE/DCE interface to the network. A restart simultaneously clears all virtual circuits at the DTE/DCE interface. At the other end of the circuit, the DTE receives the corresponding restart-indication packet from the network over the DTE/DCE interface. The format of these packets is shown in figure 9-11. The restarting-cause code is included as the fourth octet. A list of the codes is provided in table 9-6. The packet from the DTE issuing the request contains a restarting-cause code having the bit pattern 00000000 (00). Restarting-cause codes for restart-indication packets are issued by the network.

9.47 DTE and DCE Restart Confirmation.

The DTE receiving a restart-indication packet acknowledges receipt by initiating and transmitting a DTE restart confirmation over the DTE/DCE interface to the network. At the other end of the circuit, the DTE receives the corresponding DCE restart confirmation. The format of these packets is similar to the DTE and DCE interrupt-confirmation packets shown in figure 9-8.

9.48 DCE Diagnostic.

The network can initiate a diagnostic packet to supply information to the DTE on an error situation that is considered unrecoverable at the packet level. The information provided permits an analysis of the error and recovery by higher levels at the DTE, if desired or possible. The format of this packet is shown in figure 9-12. The diagnostic code is

BIT ORDER	
OCTET	8 7 6 5 4 3 2 1
1	0 0 0 1 X X X X - GFI and LCGN
2	X X X X X X X X - LCN
3	0 0 0 1 1 0 1 1 - Packet-Type Identifier
4	0 0 0 0 0 X X X - Resetting Cause
5	X X X X X X X X - Diagnostic Code (Optional)

Figure 9-10. Reset Request and Reset Indication Packet Format

Table 9-5. Resetting Cause Codes

MESSAGE	BIT PATTERN	HEX
DTE Reset	00000000	00
Out of Order	00000001	01
Remote Procedure Error	00000011	03
Local Procedure Error	00000101	05
Network Congestion	00000111	07
Remote DTE Operational	00001001	09
Network Operational	00001111	0F
Incompatible Destination	00010001	11

included as the fourth octet. A list of the codes is provided in table 9-6. If the diagnostic packet is issued in response to an erroneous packet from the DTE, the fifth through seventh octets will contain the header from the erroneous packet. No confirmation of a

receipt of a diagnostic packet need be issued by the DTE. Following issuance of a diagnostic packet, the DCE maintains the logical channel, to which the diagnostic was related, in the same state it was in at the time the packet was generated.

SECTION 5

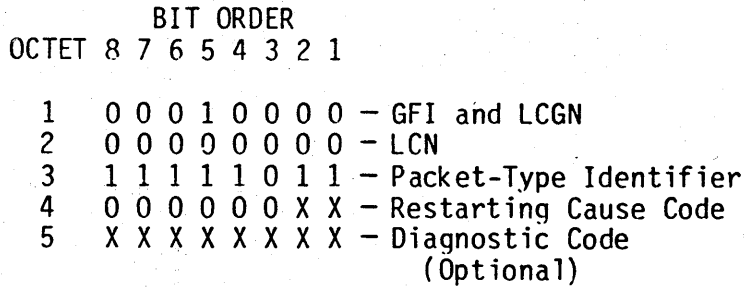

Figure 9-11. Restart Request and Restart Indication Packet Format

Table 9-6. Restarting Cause Codes

MESSAGE	BIT PATTERN	HEX
DTE Restart	00000000	00
Local Procedure Error	00000001	01
Network Congestion	00000011	03
Network Operational	00000111	07

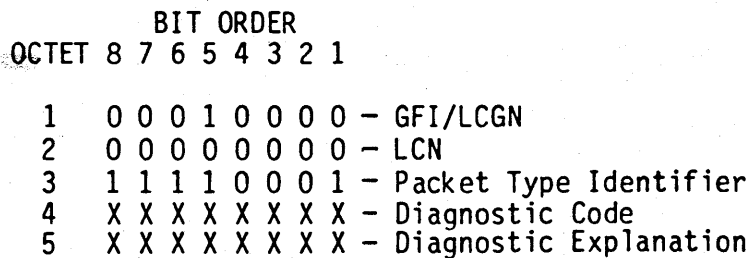

Figure 9-12. DCE Diagnostic Packet Format

D. Operation

9.49 LINE MONITORING. The 802A will automatically monitor the data on either an HDLC or bisync X.25 interface. HDLC automonitor will default to suppression of 7E, 7E and FCS counters enabled. This will limit storage of flags between frames to one and will enable FCS checking.

9.50 ANALYSIS. Analysis of the frame- and packet-level fields of each frame is performed in the capture mode. After entering the capture mode, by pressing CAPTURE, pressing the 5 key will initiate the X.25 analysis function. The X.25 analysis page with the description of the first frame in the capture buffer is displayed. (See figure 9-13.) The three digit number at the left of the screen identifies the frame in the capture buffer. The

description appears under FROM DTE or FROM DCE, dependent on the source of the frame. (See figure 9-14.) The display format of each frame type is shown in table 9-7. The frame can be displayed in hexadecimal following the description by pressing the CODE/HEX key. Additional frames can be sequentially displayed manually by pressing the SCROLL UP key or automatically by pressing SHIFT followed by SCROLL UP. Press SCROLL UP to stop the automatic scroll.

9.51 Scrolling through the frames can be reversed by pressing SCROLL down or SHIFT and SCROLL down. The display can be returned to the top of the capture buffer by pressing SCROLL HOME.

9.52 The capture buffer display can be returned by pressing PAGE.

```

                                X.25 ANALYSIS
FROM DTE                          FROM DCE
001 7 B RR(0) P
    E
002
003 7 B I (0,0) P
    E      D Q 00 001
          CALL RQST
004
005 7 B I (1,1) P
    E      D Q 00 001
          DATA (0,0)M
006
                                7 A RR (0) P
                                E
                                7 B I(0,1)F
                                E      D Q 00 001
                                CALL CONTD
                                7 A I (1,2) P
                                E      D Q 00 001
                                RR(1)

```

Figure 9-13. X.25 Analysis Page

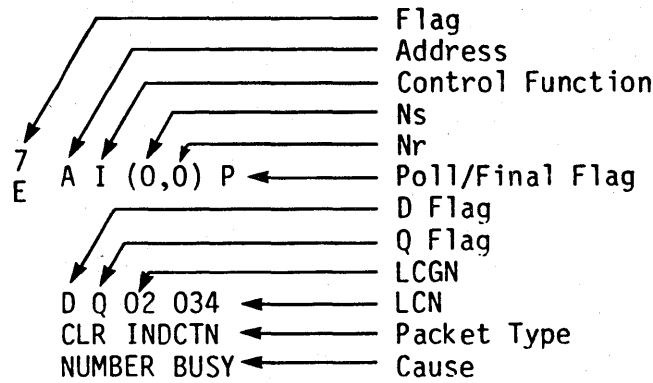

Figure 9-14. Typical Display Format

Table 9-7. X.25 Analysis Display Formats

DISPLAY	HEXADECIMAL
SUPERVISORY	
Receive Ready (RR)	
7 E B RR (0) P	7007 E11E
Receive Not Ready (RNR)	
7 E B RNR (0) P	7007 E15E
Reject (REJ)	
7 E B REJ (0) P	7007 E19E
UNNUMBERED	
Set Asynchronous Response Mode	
7 E B SARM P	7007 E1FE
Set Asynchronous Balanced Mode (SABM)	
7 E B SABM P	7027 E1FE

Table 9-7 X.25 Analysis Display Formats (Cont)

Disconnect (DISC)		
7	B DISC P	7047
E		E13E
Unnumbered Acknowledge (UA)		
7	A UA F	7067
E		E33E
Disconnected Mode (DM)		
7	A DM F	7007
E		E3FE
Command or Frame Reject (CMDR or FRMR)		
7	A CMDR F	7087
E		E37E
INFORMATION		
Call Request		
7	B I (0,0) P	7001007
E	Q D 00 000	E10008E
	CALL RQST	
Incoming Call		
7	A I (0,0) P	7001007
E	Q D 00 000	E30008E
	INCOMING CALL	
Call Accepted		
7	A I (0,0) F	7001007
E	Q D 00 000	E3000FE
	CALL ACPTD	
Call Connected		
7	B I (0,0) F	7001007
E	Q D 00 000	E1000FE
	CALL CONTD	
Clear Request (DTE Clearing)		
7	B I (0,0) P	70010107
E	Q D 00 000	E100030E
	CLR RQST	
	DTE CLEARING	

SECTION 5

Table 9-7 X.25 Analysis Display Formats (Cont)

Clear Indication
(Number Busy)

7	A I (0,0) P	70010107
E	Q D 00 000	E300031E
	CLR INDCTN	
	NUMBER BUSY	

(Invalid Facility Request)

7	A I (0,0) P	70010107
E	Q D 00 000	E300033E
	CLR INDCTN	
	INVALID CALL	

(Network Congestion)

7	A I (0,0) P	70010107
E	Q D 00 000	E300035E
	CLR INDCTN	
	NETWORK CONGESTION	

(Out of Order)

7	A I (0,0) P	70010107
E	Q D 00 000	E300039E
	CLR INDCTN	
	OUT OF ORDER	

(Access Barred)

7	A I (0,0) P	70010107
E	Q D 00 000	E300338E
	CLR INDCTN	
	ACCESS BARRED	

(Not Obtainable)

7	A I (0,0) P	70010107
E	Q D 00 000	E30003DE
	CLR INDCTN	
	NOT OBTAINABLE	

(Remote Procedure Error)

7	A I (0,0) P	70010117
E	Q D 00 000	E300031E
	CLR INDCTN	
	REMOTE PROCEDURE ERROR	

Table 9-7 X.25 Analysis Display Formats (Cont)

(Local Procedure Error)		
7	A I (0,0) P	70010117
E	Q D 00 000	E300033E
	CLR INDCTN	
	LOCAL PROCEDURE ERROR	
(RPOA Out of Order)		
7	A I (0,0) P	70010117
E	Q D 00 000	E300035E
	CLR INDCTN	
	RPOA OUT OF ORDER	
(Reverse Charging Acceptance Not Subscribed)		
7	A I (0,0) P	70010117
E	Q D 00 000	E300039E
	CLR INDCTN	
	NUMBER REFUSING COLLECT	
	CONNECTION	
(Incompatible Distinction)		
7	A I (0,0) P	70010127
E	Q D 00 000	E300031E
	CLR INDCTN 2	
	1	
(Fast Select Acceptance Not Subscribed)		
7	A I (0,0) P	70010127
E	Q D 00 000 ₂	E300039E
	CLR INDCTN ₉	
DTE Clear Confirmation		
7	A I (0,0) F	7001017
E	Q D 00 000	E30007E
	CLR CNFMN	
DCE Clear Confirmation		
7	B I (0,0) F	7001017
E	Q D 00 000	E10007E
	CLR CNFMN	
DTE Data		
7	B I (0,0) P	700100X-X7
E	Q D 00 000	E10000X-XE
	DATA (0,0)M	
DCE Data		
7	A I (0,0) P	700100X-X7
E	Q D 00 000	E30000X-XE
	DATA (0,0)M	

SECTION 5

Table 9-7 X.25 Analysis Display Formats (Cont)

DTE Interrupt		
7 E	B I (0,0) P Q D 00 000 INTERRUPT	7001027 E10003E
DCE Interrupt		
7 E	A I (0,0) P Q D 00 000 INTERRUPT	7001027 E30003E
DTE Interrupt Confirmation		
7 E	A I (0,0) F Q D 00 000 INT CNFMN	7001027 E30007E
DCE Interrupt Confirmation		
7 E	B I (0,0) F Q D 00 000 INT CNFMN	7001027 E10007E
DTE Receive Ready (RR)		
7 E	B I (0,0) P Q D 00 000 RR (0)	7001007 E10001E
DCE Receive Ready (RR)		
7 E	A I (0,0) P Q D 00 000 RR (0)	7001007 E30001E
DTE Receive Not Ready (RNR)		
7 E	B I (0,0) P Q D 00 000 RNR (0)	7001007 E10005E
DCE Receive Not Ready (RNR)		
7 E	A I (0,0) P Q D 00 000 RNR (0)	7001007 E30005E
DTE Reject (REJ)		
7 E	B I (0,0) P Q D 00 000 REJ (0)	7001007 E10009E

Table 9-7 X.25 Analysis Display Formats (Cont)

Reset Request (DTE Reset)		
7	B I (0,0) P	70010107
E	Q D 00 000	E1000B0E
	RESET RQST	
	DTE RESET	
Reset Indication (Out of Order)		
7	A I (0,0) P	70010107
E	Q D 00 000	E3000B1E
	REST INDCTN	
	DTE OUT OF ORDER	
(Remote Procedure Error)		
7	A I (0,0) P	70110107
E	Q D 00 000	E3000B3E
	REST INDCTN	
	REMOTE PROCEDURE ERROR	
(Local Procedure Error)		
7	A I (0,0) P	70010107
E	Q D 00 000	E3000B5E
	REST INDCTN	
	LOCAL PROCEDURE ERROR	
(Network Congestion)		
7	A I (0,0) P	70010107
E	Q D 00 000	E3000B7E
	REST INDCTN	
	NETWORK CONGESTION	
(Remote DTE Operational)		
7	A I (0,0) P	70010107
E	D Q 00 000	E3000B9E
	RESET INDCTN 0	
	9	
(Network Operational)		
7	A I (0,0) P	70010107
E	D Q 00 000	E3000BFE
	RESET INDCTN 0	
	F	
(Incompatible Destination)		
7	A I (0,0) P	70010117
E	D Q 00 000	E3000B1E
	RESET INDCTN 1	
	1	

SECTION 5

Table 9-7 X.25 Analysis Display Formats (Cont)

DTE Reset Confirmation		
7	A I (0,0) F	7001017
E	Q D 00 000	E3000FE
	RESET CNFMN	
DCE Reset Confirmation		
7	B I (0,0) F	7001017
E	Q D 00 000	E1000FE
	RESET CNFMN	
Restart Request (DTE Restart)		
7	B I (0,0) P	70010F07
E	Q D 00 000	E1000B0E
	RST RQST	
Restart Indication (Local Procedure Error)		
7	A I (0,0) P	70010F07
E	Q D 00 000	E3000B1E
	RST INDCTN	
	LOCAL PROCEDURE ERROR	
(Network Operational)		
7	A I (0,0) P	70010F07
E	Q D 00 000	E3000B2E
	RST INDCTN	
	LINK OPERATIONAL	
(Network Congestion)		
7	A I (0,0) P	70010F07
E	Q D 00 000	E3000B3E
	RST INDCTN	
	NETWORK CONGESTION	
DTE Restart Confirmation		
7	A I (0,0) F	70010F7
E	Q D 00 000	E3000FE
	RST CNFMN	
DCE Restart Confirmation		
7	B I (0,0) F	70010F7
E	Q D 00 000	E1000FE
	RST CNFMN	

**802A DATA LINK MONITOR
APPENDIX A
QUICK REFERENCE GUIDE**

1. GENERAL

1.01 This appendix provides an operating flow chart for the 802A Data Link Monitor. (See figure 1.)





2. CONTENT

2.01 The content of the flow chart is as follows:

Sheet	Function
1	Automonitor Mode and Run Mode Functions
2	Capture Mode Functions
3 thru 7	Manual Step Mode, Line/Display Parameters
9 thru 12	Manual Step Mode, Start/Stop Parameters
13 thru 15	Manual Step Mode, Counter Selections
16 thru 19	Tape Mode Functions

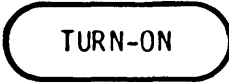
3. SYMBOLOGY

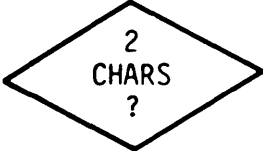
3.01 The following symbols are used in this flow chart:

- (a)  - Start.
- (b)  - Equipment action or display.
- (c)  - Operator action. Press key indicated.
- (d)  Decision
- (e)  SH1 - Connection to another location on the drawing. Destinations are identified by sheet number.

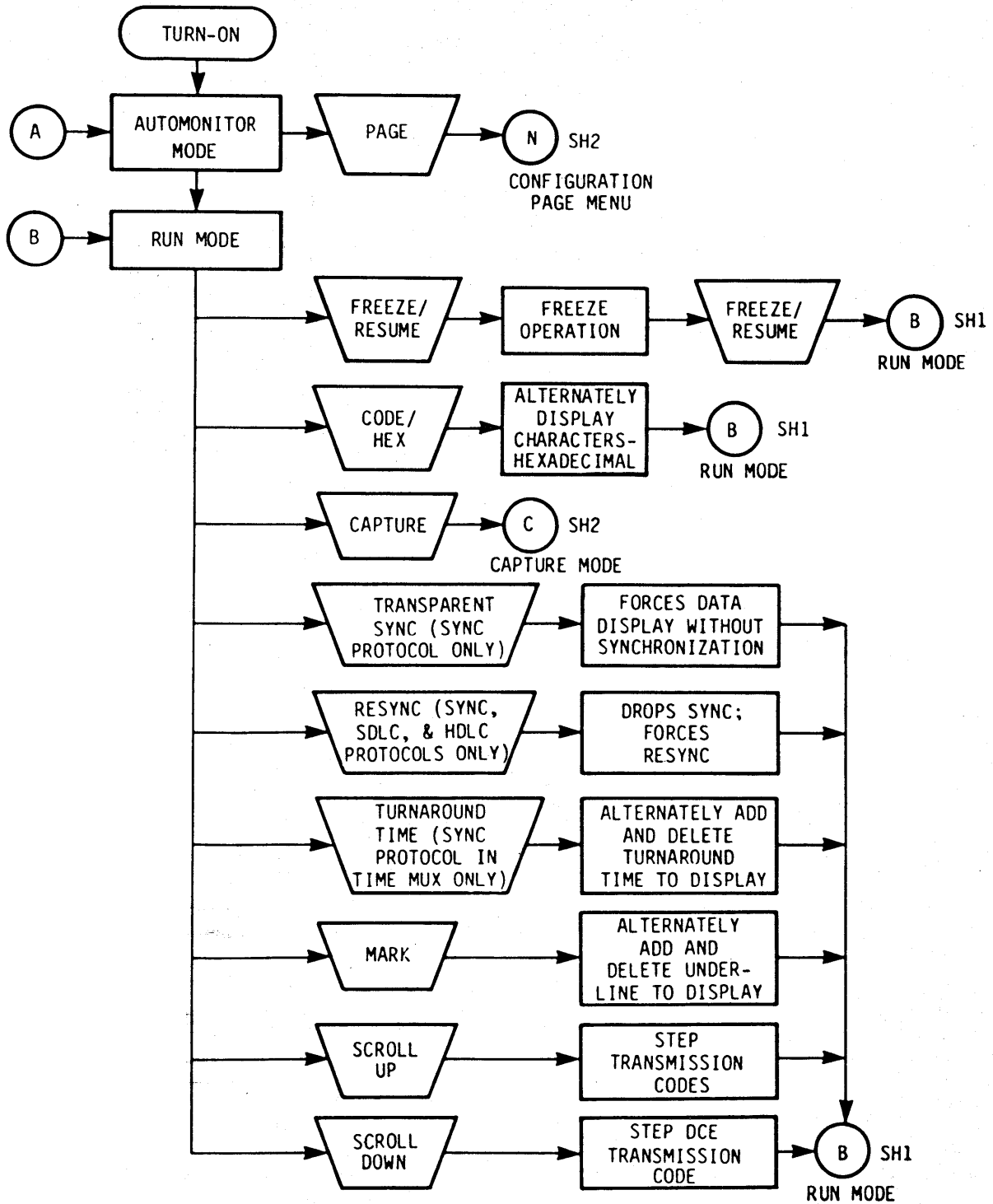

Figure 1. Operating Flow Chart (Sheet 1 of 19)

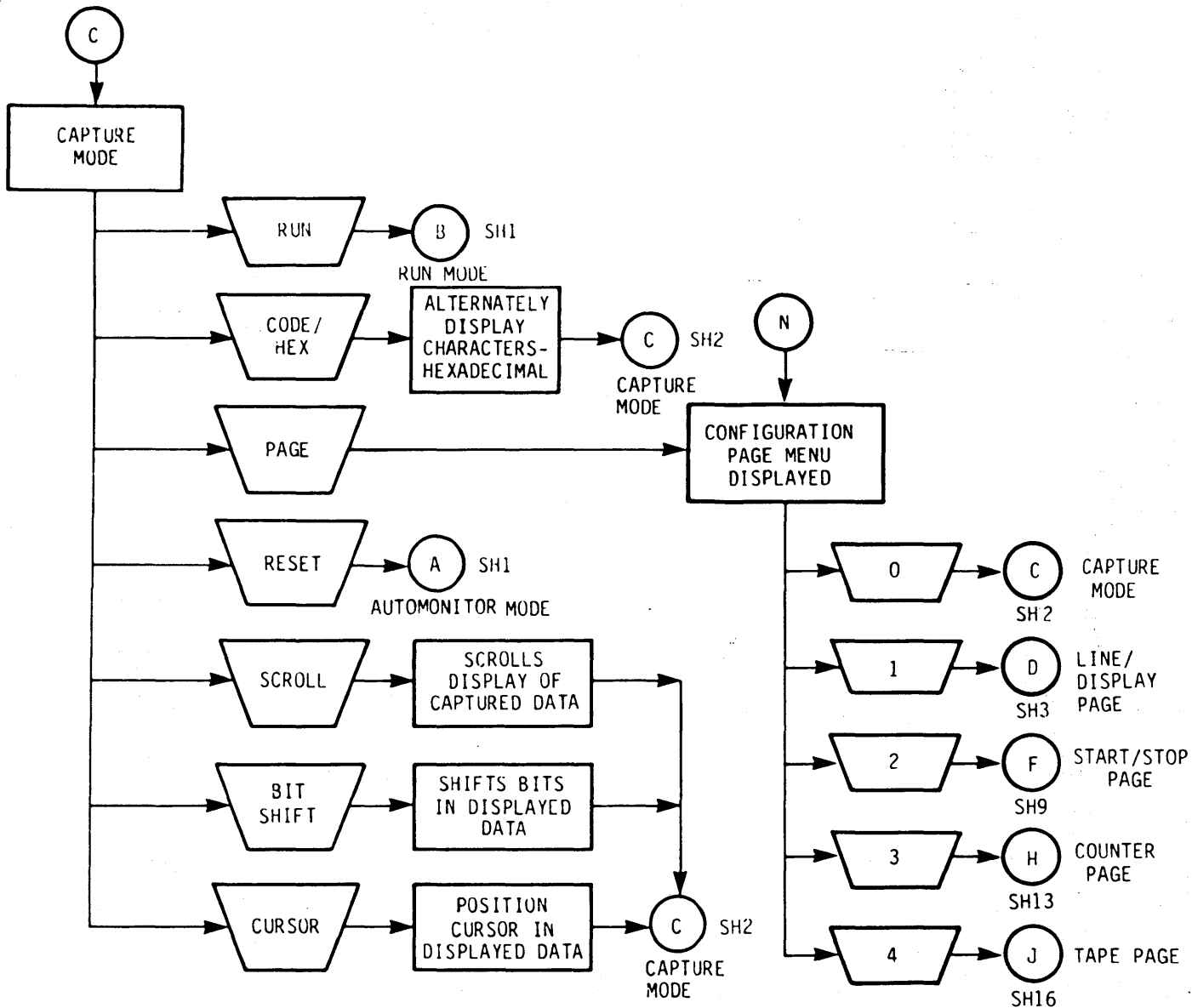

Figure 1. Operating Flow Chart (Sheet 2 of 19)

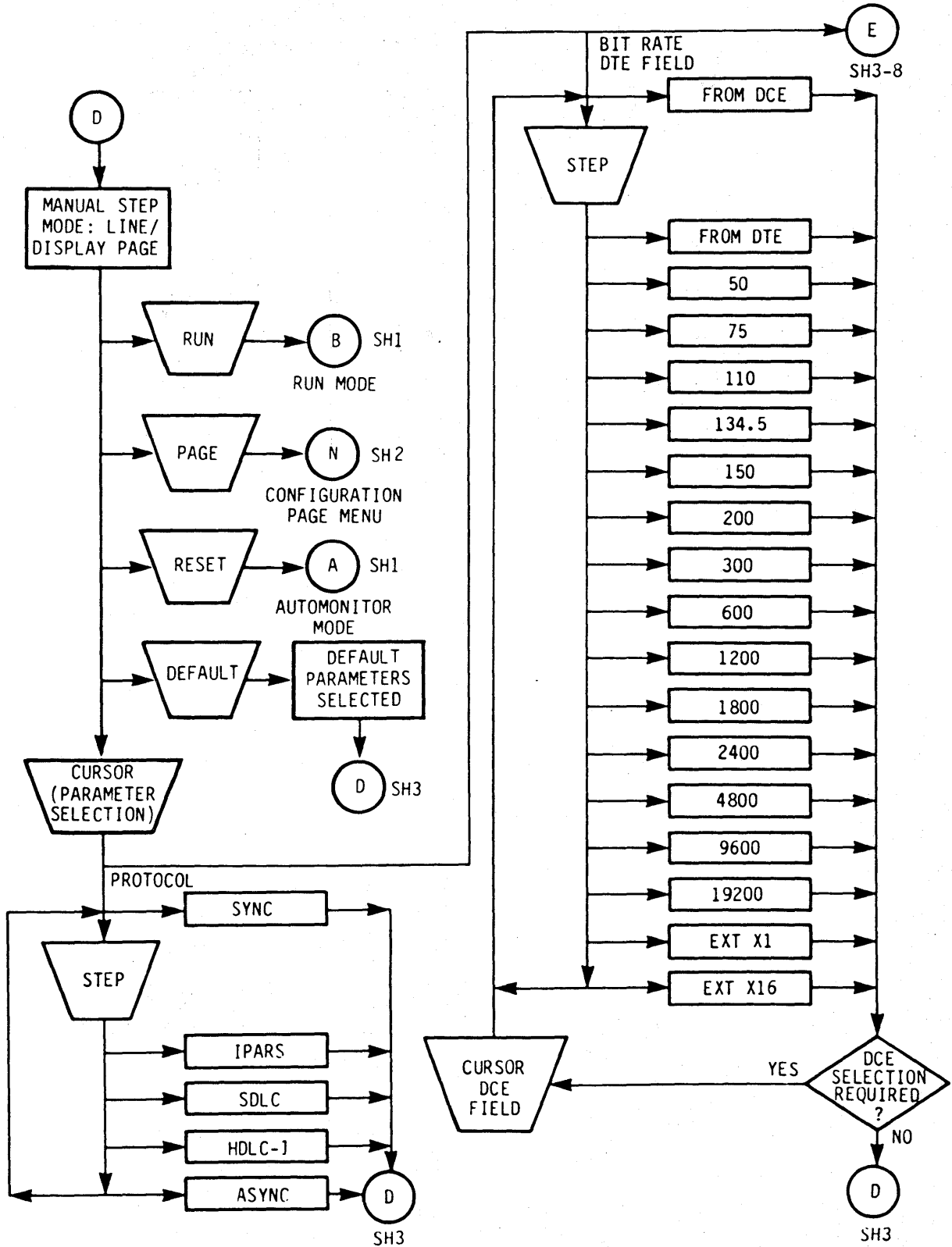

Figure 1. Operating Flow Chart (Sheet 3 of 19)

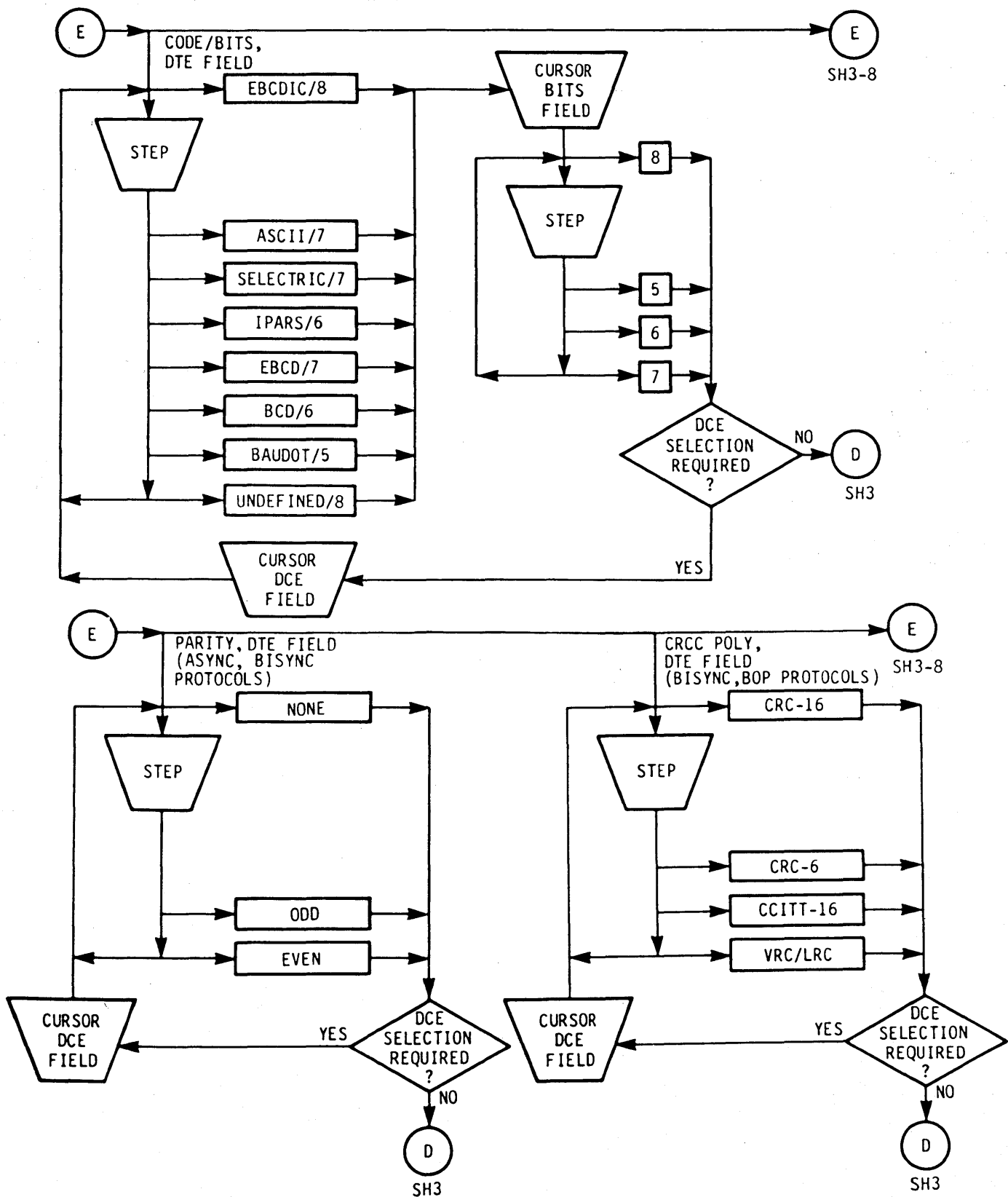

Figure 1. Operating Flow Chart (Sheet 4 of 19)

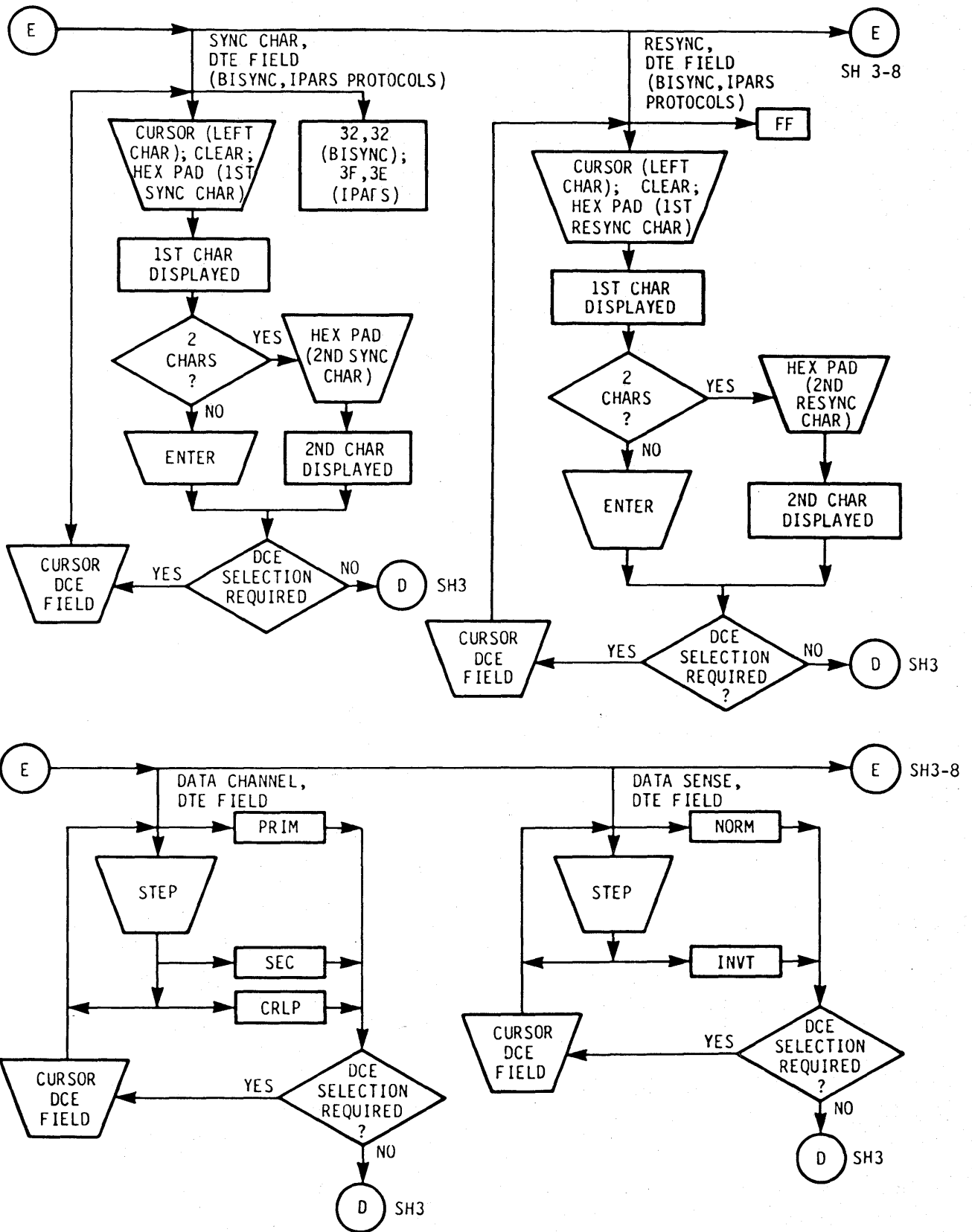

Figure 1. Operating Flow Chart (Sheet 5 of 19)

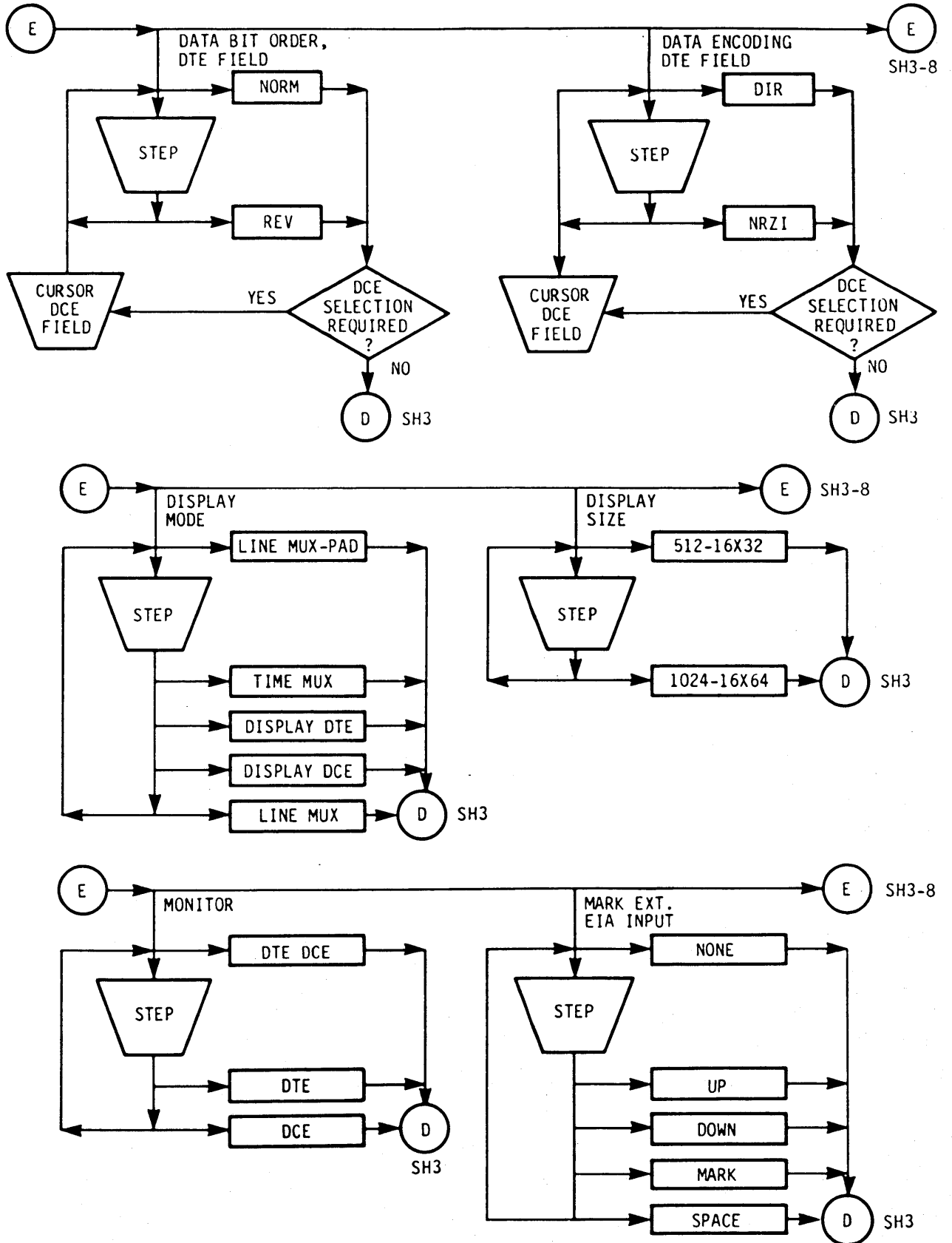

Figure 1. Operating Flow Chart (Sheet 6 of 19)

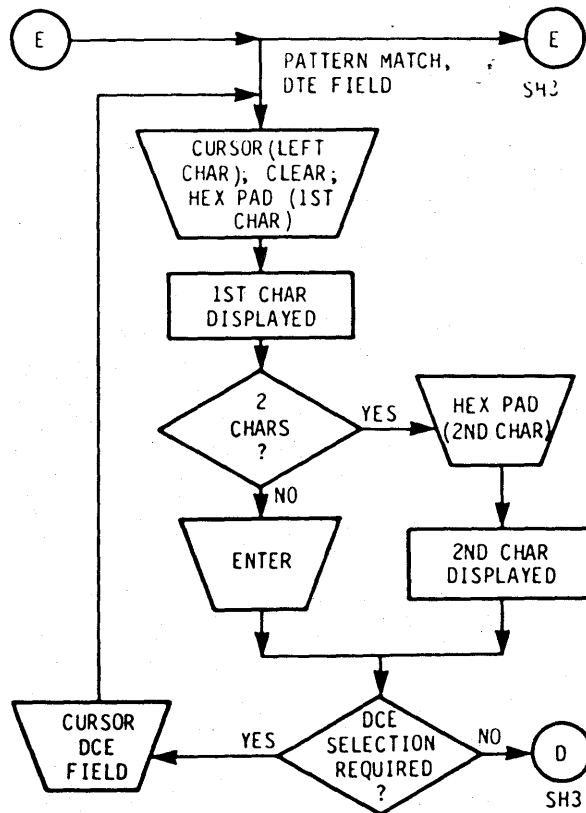
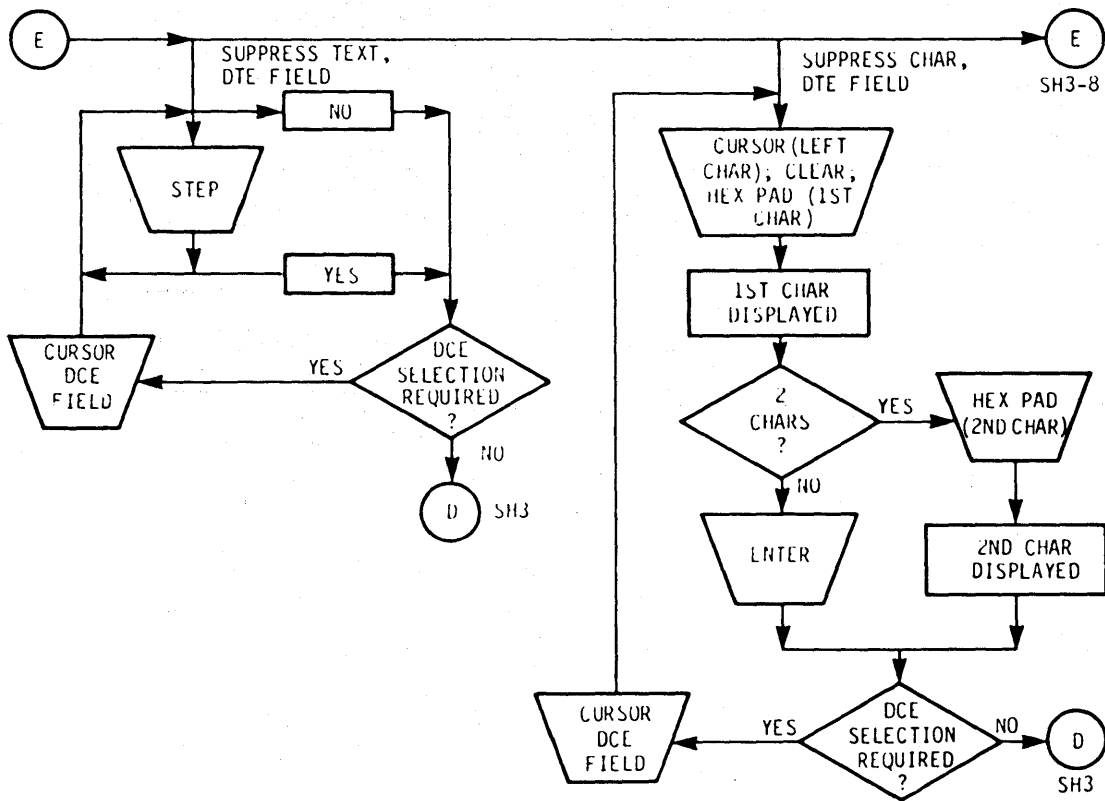

Figure 1. Operating Flow Chart (Sheet 7 of 19)

(Deleted)

Figure 1. Operating Flow Chart (Sheet 8 of 19)

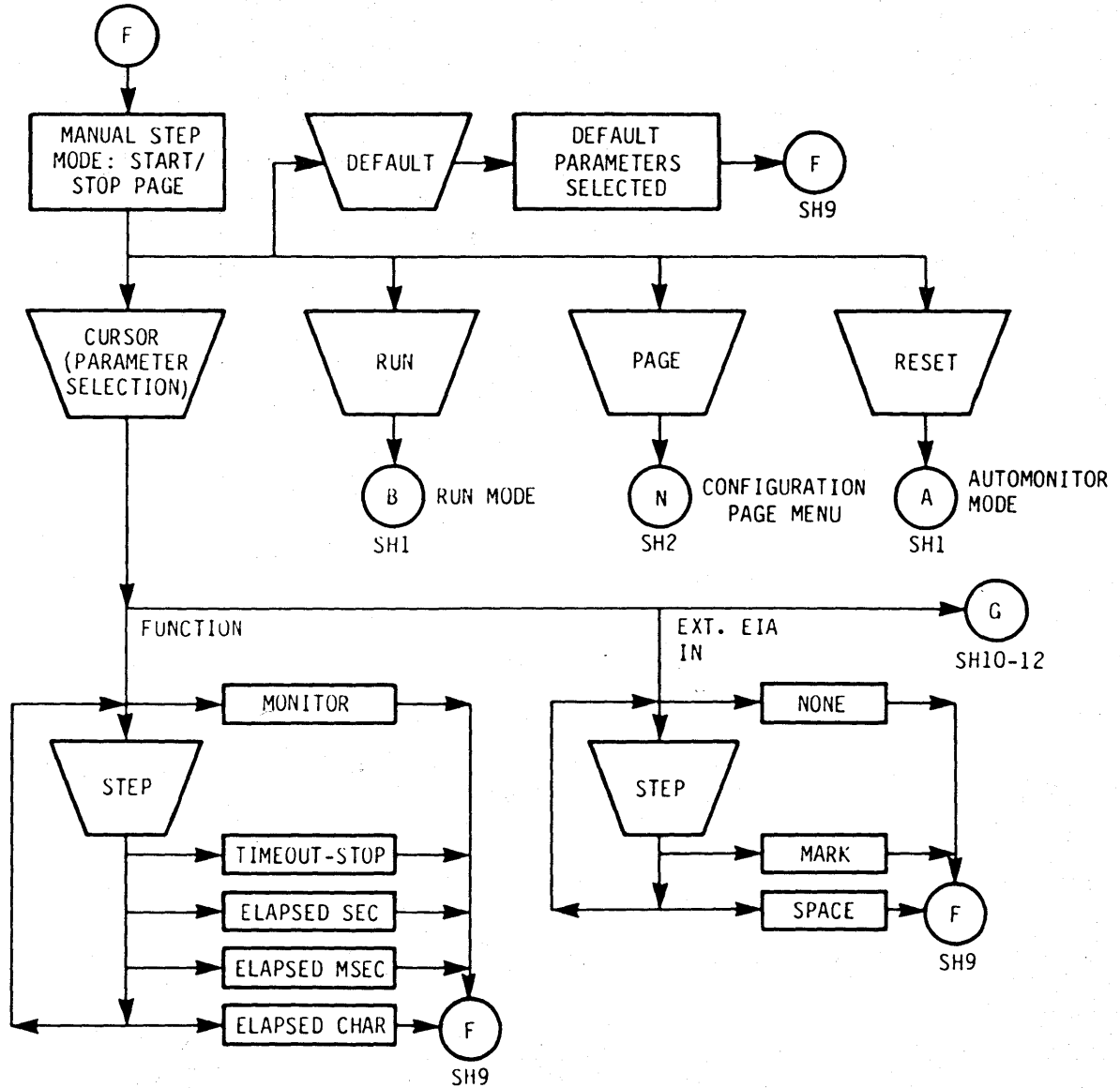

Figure 1. Operating Flow Chart (Sheet 9 of 19)

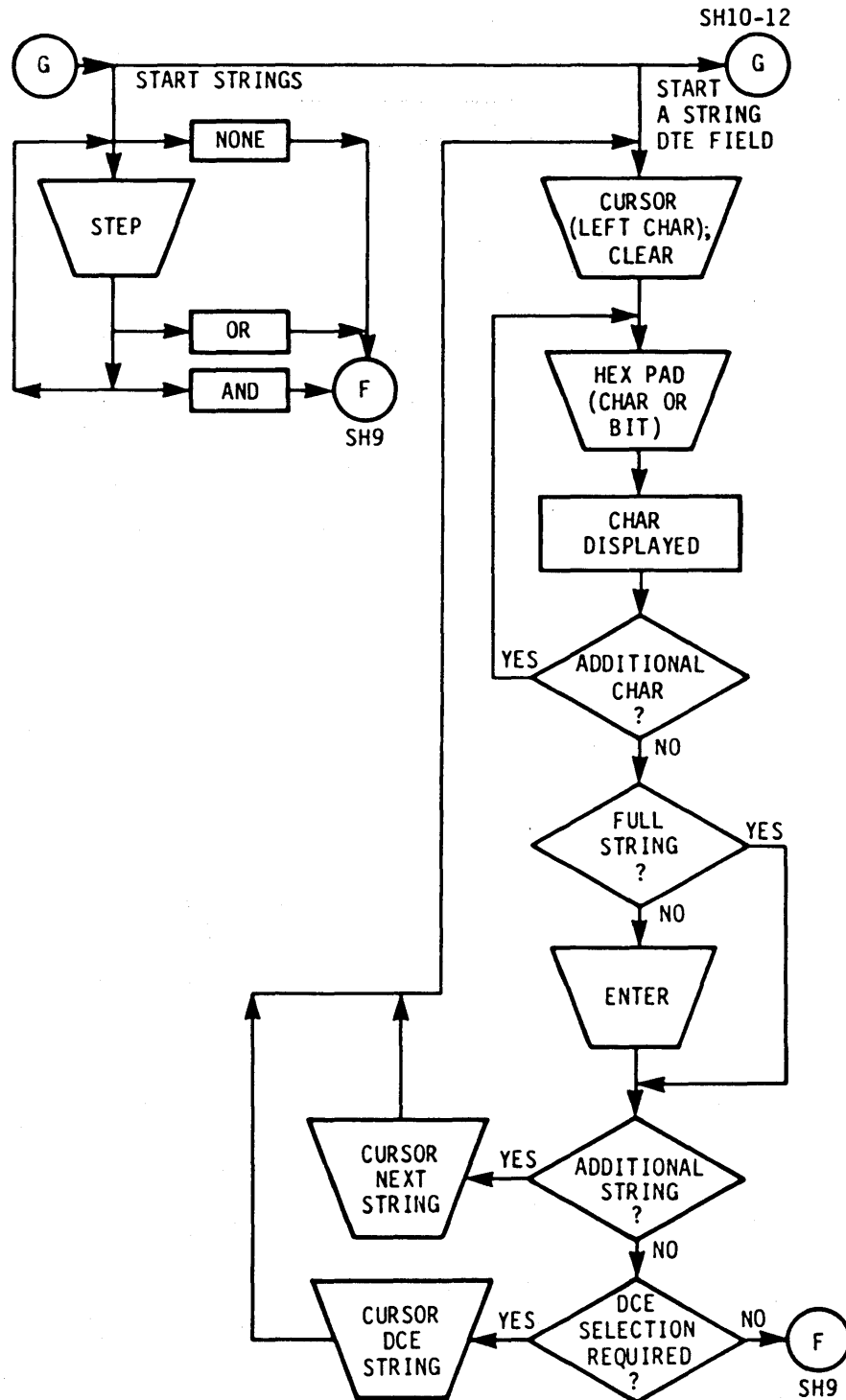

Figure 1. Operating Flow Chart (Sheet 10 of 19)

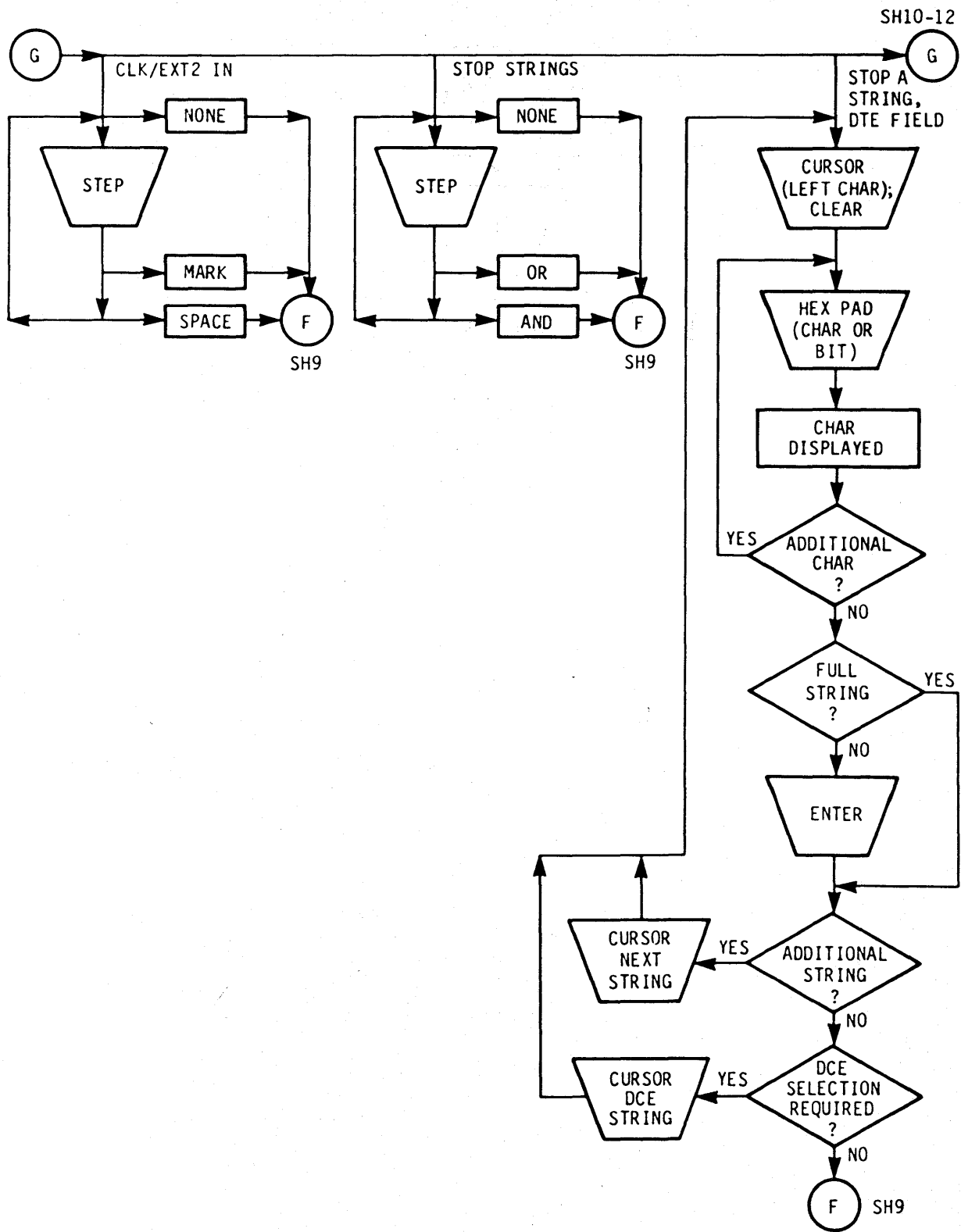

Figure 1. Operating Flow Chart (Sheet 11 of 19)

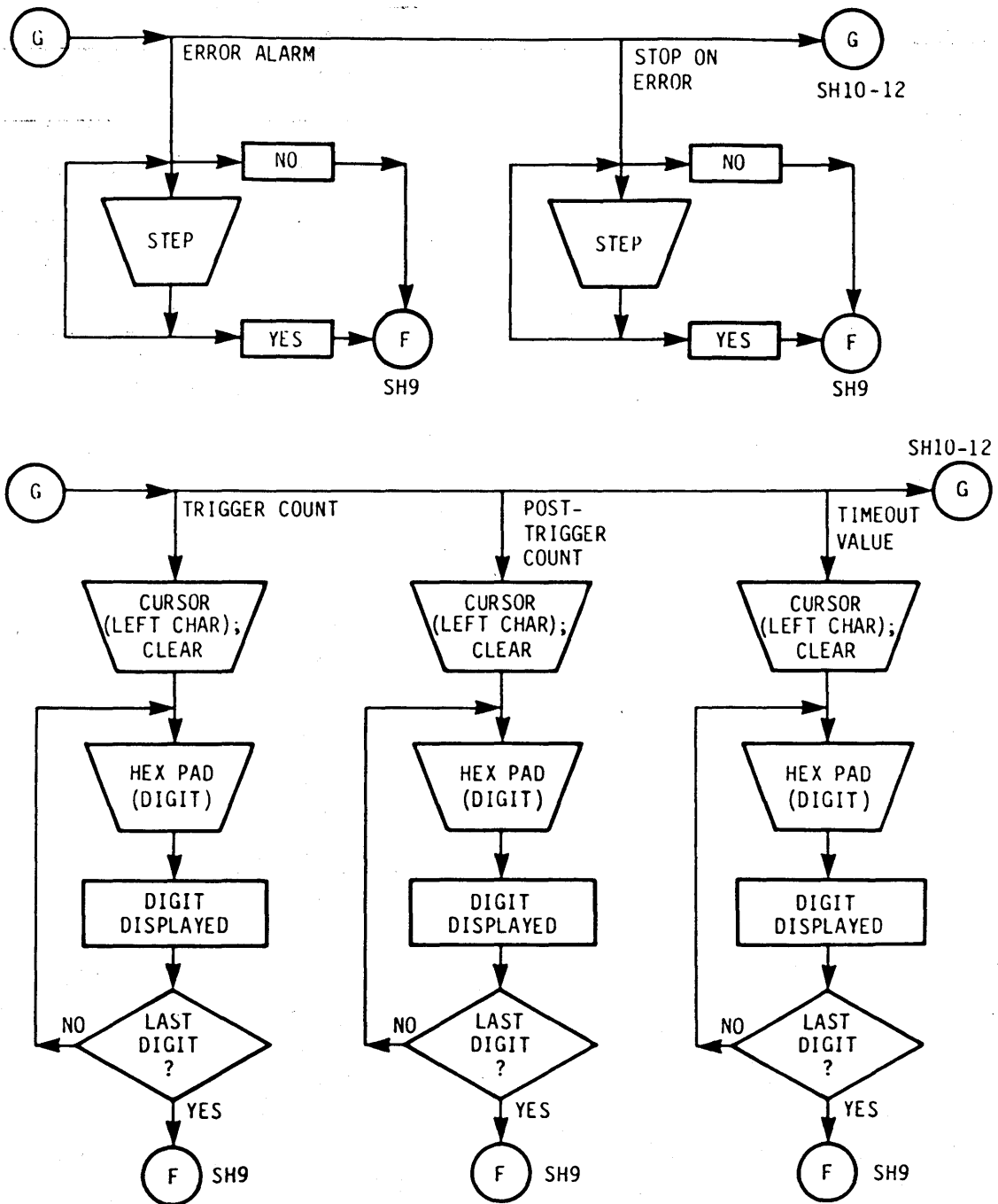

Figure 1. Operating Flow Chart (Sheet 12 of 19)

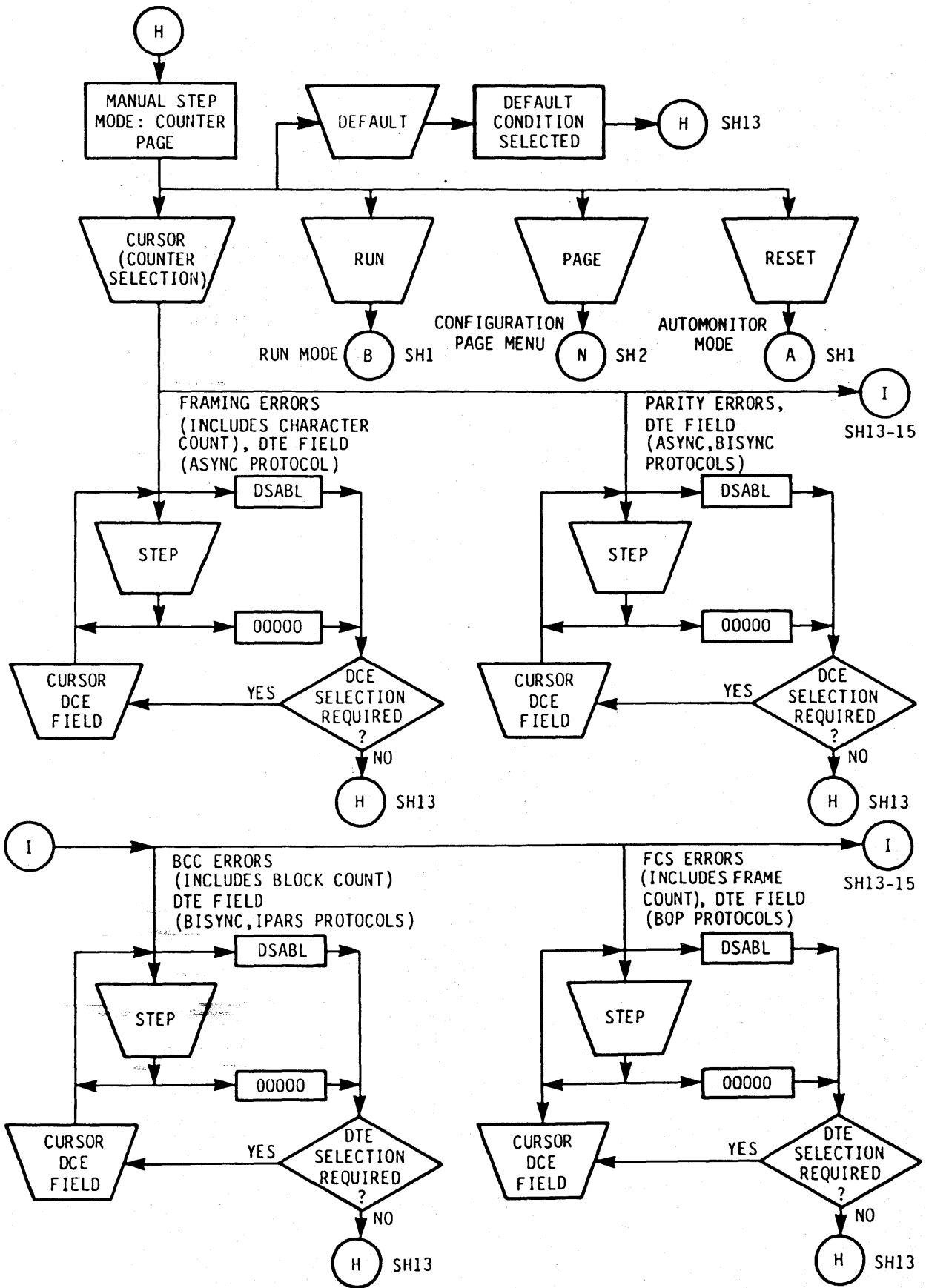

Figure 1. Operating Flow Chart (Sheet 13 of 19)

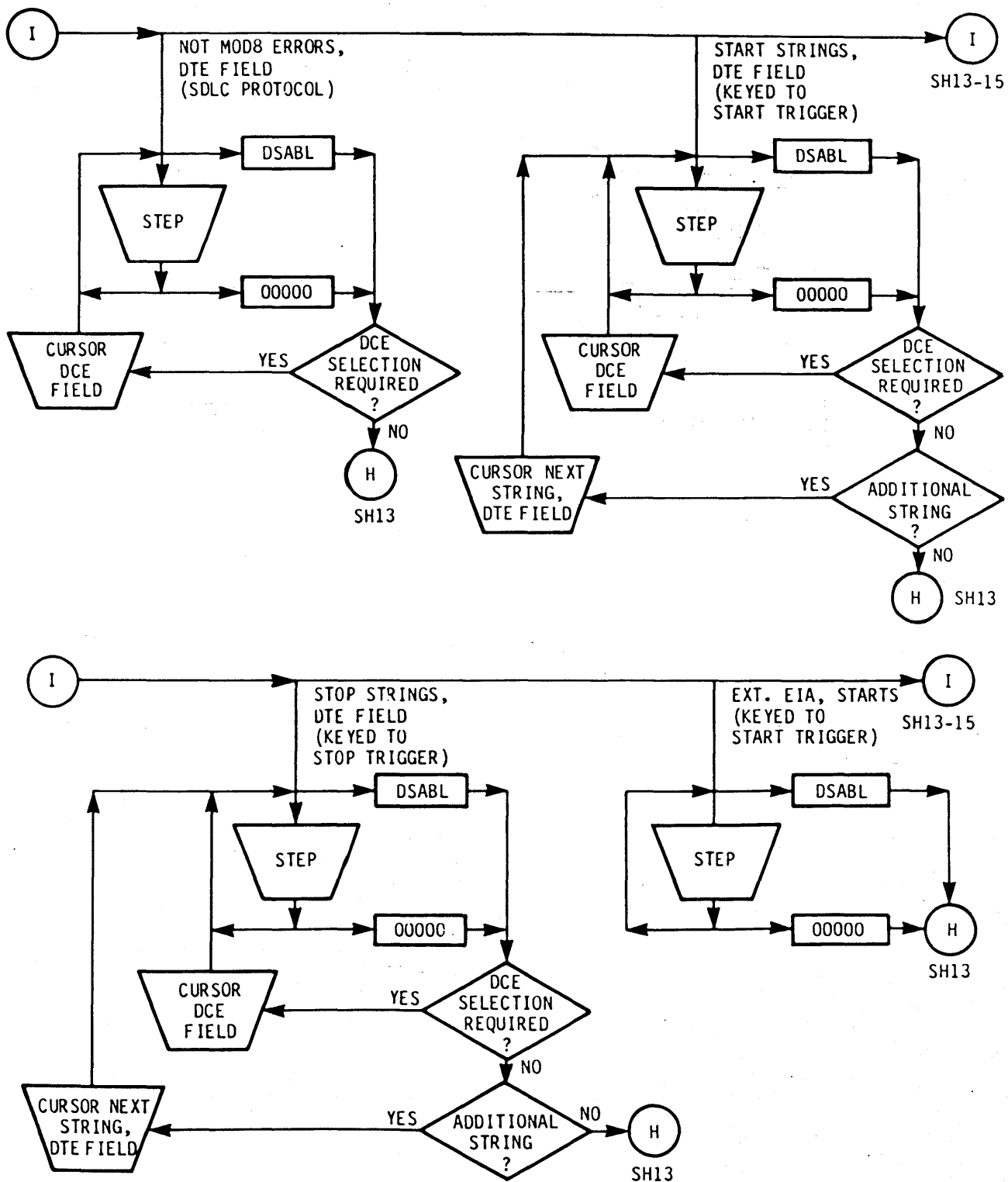

Figure 1. Operating Flow Chart (Sheet 14 of 19)

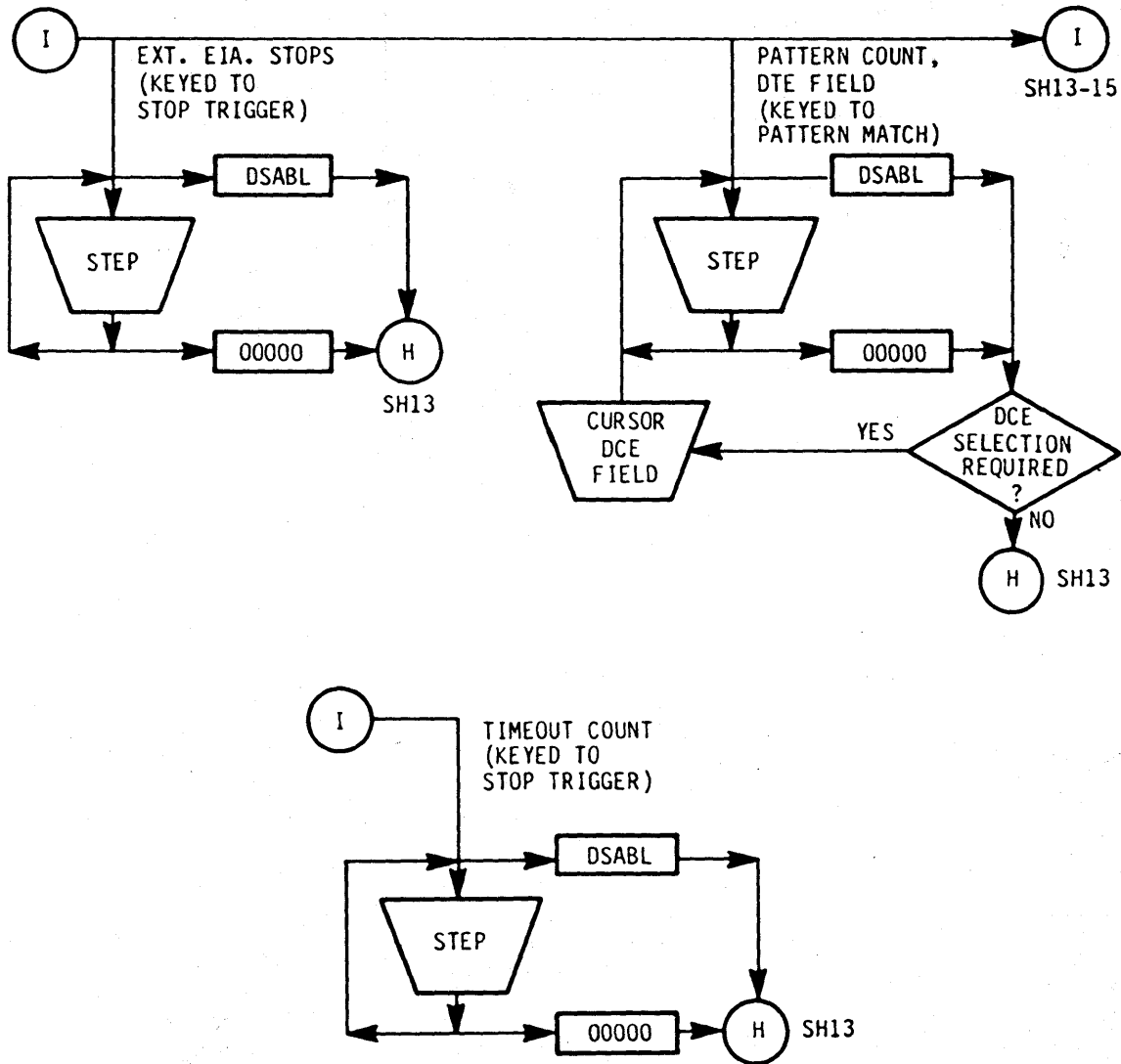

Figure 1. Operating Flow Chart (Sheet 15 of 19)

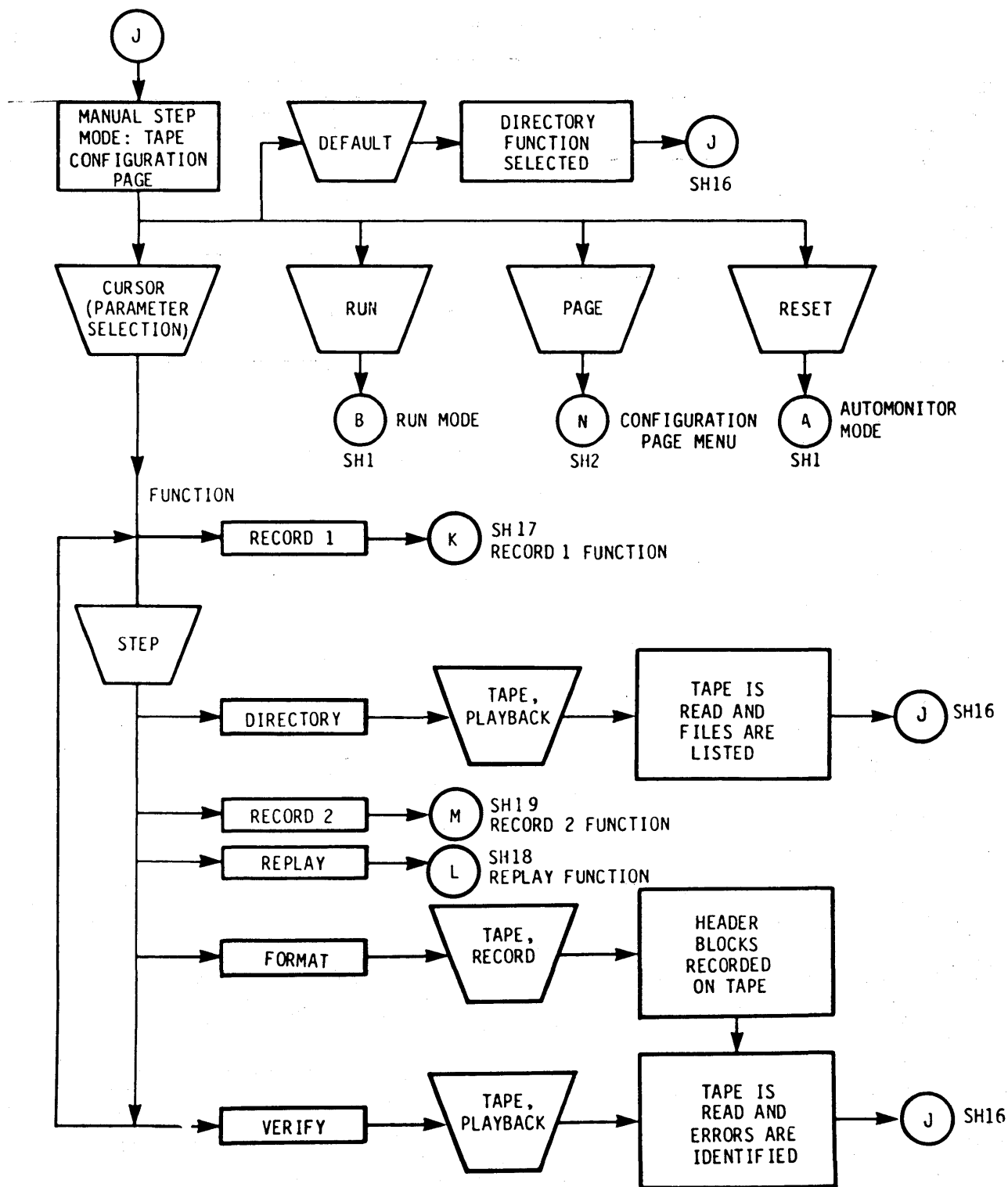

Figure 1. Operating Flow Chart (Sheet 16 of 19)

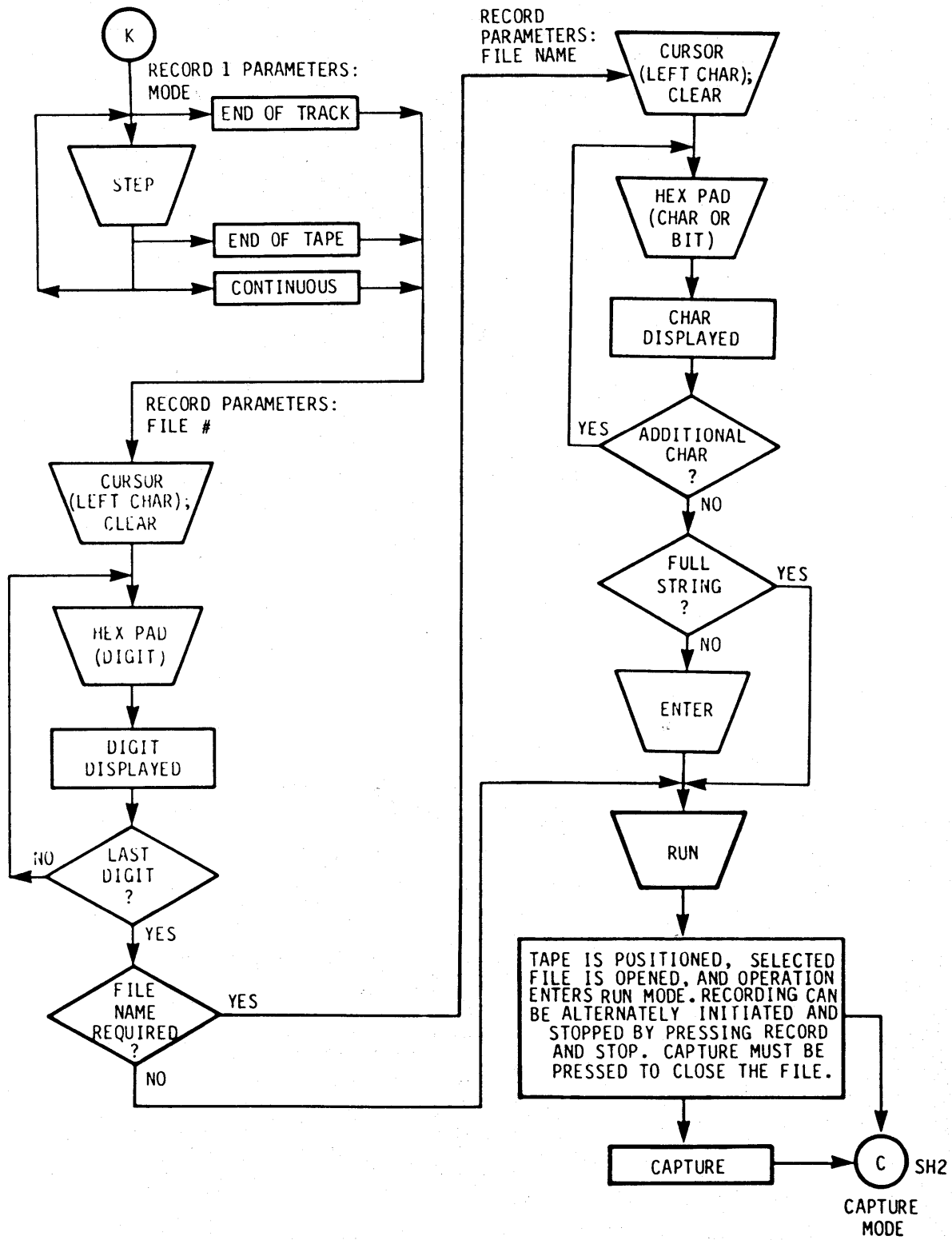

Figure 1. Operating Flow Chart (Sheet 17 of 19)

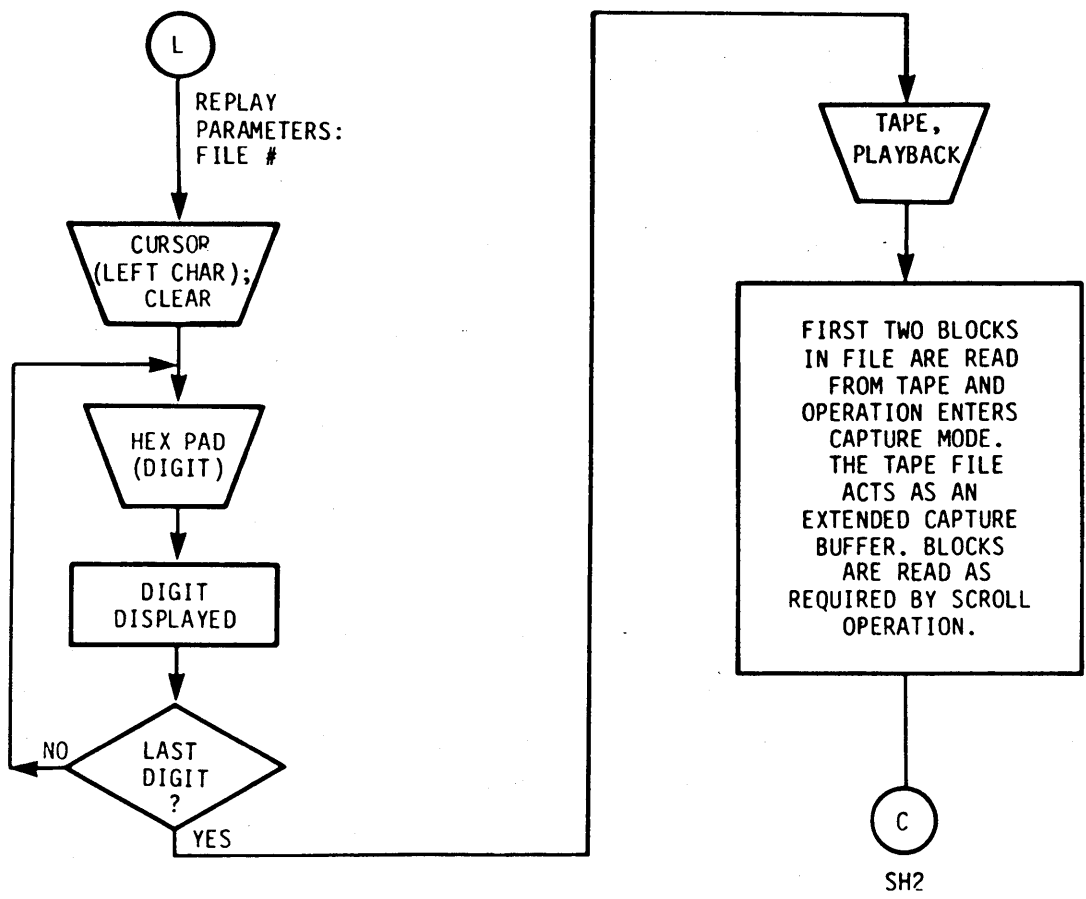

Figure 1. Operating Flow Chart (Sheet 18 of 19)

APPENDIX A

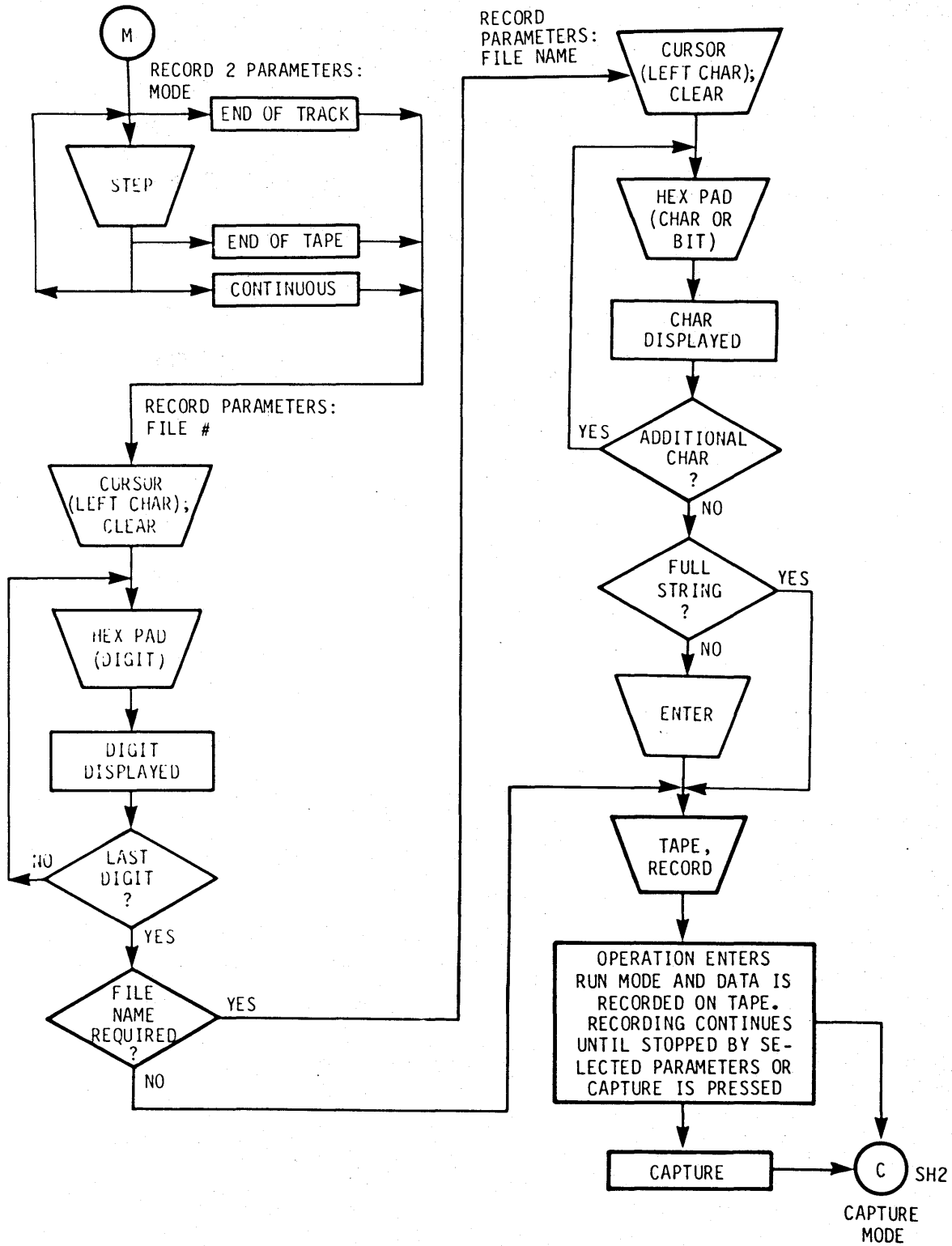

Figure 1. Operating Flow Chart (Sheet 19 of 19)

802A DATA LINK MONITOR
APPENDIX B
ERROR MESSAGE DESCRIPTIONS

1. GENERAL

1.01 This appendix provides descriptions of the error messages generated by the 802A Data Link Monitor. Two types of error messages are provided: manual stop errors and tape controller errors.

2. MANUAL STEP ERRORS

2.01 The following error messages are applicable to the manual step mode.

2.02 ERROR 01. Key pressed initiated no action.

2.03 ERROR 02. Cursor not on a defined or relevant field.

2.04 ERROR 09. Key value exceeded bit field range.

2.05 ERROR 0A. Key value exceeded hexadecimal field range.

2.06 ERROR 0B. Key value exceeded specified character size.

2.07 ERROR 0C. Key value exceeded decimal field range.

3. TAPE CONTROLLER ERRORS

3.01 Tape controller error messages are classified as system errors, format errors, buffer definition errors, position errors, open file errors, or read/write errors.

A. Buffer Definition Errors

3.02 ERROR 21. Buffer ID greater than $0F_{16}$.

3.03 ERROR 22. Segment count greater than 03_{16} .

3.04 ERROR 23. Total buffer size greater than 880_{16} .

3.05 ERROR 24. Specified buffer previously defined.

3.06 ERROR 25. Buffer segment crosses 32K boundary.

B. Format Errors

3.07 The tape controller format errors are as follows.

3.08 ERROR 30. Load point not found.

3.09 ERROR 31. Load point incorrect.

3.10 ERROR 32. Block ID not found.

3.11 ERROR 33. Track ID incorrect.

3.12 ERROR 34. Block ID incorrect.

C. Position Errors

3.13 The tape controller position errors are as follows.

3.14 ERROR 40. Timeout; loadpoint not found.

3.15 ERROR 41. Incorrect loadpoint.

3.16 ERROR 45. No file found.

D. Open File Errors

3.17 The tape controller open file errors are as follows.

3.18 ERROR 50. Record mode greater than maximum (two).

APPENDIX B

- 3.22 ERROR 60. Undefined buffer.
- 3.23 ERROR 61. Incorrect track.
- 3.24 ERROR 62. Incorrect block.
- 3.25 ERROR 63. Overrun.
- 3.26 ERROR 64. Checksum error in header.
- 3.27 ERROR 65. Checksum error in data.
- 3.28 ERROR 66. Read timeout.
- 3.29 ERROR 67. Write timeout.

F. System Errors

- 3.30 The tape controller system error messages are as follows.
- 3.31 ERROR F0. Command error (CMDERR).
- 3.32 ERROR F1. No tape (NOTAPE).
- 3.33 ERROR F2. Write protect (FPERR).
- 3.34 ERROR F3. Parameter error (PRMERR).
- 3.35 ERROR F4. Controller busy.
- 3.36 ERROR FF. Fatal Error (FTLERR).

802A DATA LINK MONITOR
APPENDIX C
TRANSMISSION CODE DESCRIPTIONS

APPENDIX C

1. GENERAL

1.01 This appendix describes the transmission codes available for use with the 802A Data Link Monitor. All transmission codes listed below may be used in both synchronous and asynchronous modes. While each of the codes is normally associated with a particular character length, the monitor allows the bit length of each code to be user selected. ASCII, for example, which is normally a seven bit transmission code, may be programmed for 5, 6, 7, or 8 bit character length.

1.02 A transmission code conversion chart is provided as table 1. The character sets for each code are listed in hexadecimal (HEX) code order. Where a character is not defined in a transmission code the hexadecimal code is repeated for that character. Abbreviations used in this table are defined in table 2.

1.03 ASCII: American National Standard Code for Information Interchange (ASCII) is a 7-bit transmission code defined by the American National Standards Institute.

1.04 Baudot: Baudot is the international standard teletype transmission code and is defined as CCITT International Alphabet No. 2. Baudot is a 5-bit, duocase code. The shift charac-

ters are letter shift (LS) for letter case (LC) and figure shift (FS) for figure case (FC).

1.05 EBCD: Extended binary-coded decimal (EBCD) is a 7-bit duocase code used in IBM 2740 communication terminals. The shift characters are upper case (UC) and lower case (LC).

1.06 EBCDIC: Extended binary-coded-decimal interchange code (EBCDIC) is an 8-bit transmission code developed by IBM.

1.07 IPARS: IPARS is a 6-bit transmission code used with International Passenger Airlines Reservation System (IPARS) protocol.

1.08 SBT. Six-bit transcode (SBT) is a six-bit binary-coded decimal (BCD) transmission code developed by IBM.

1.09 Selectric: Selectric is a 7-bit duocase code. The shift characters are upper case (UC) and lower case (LC).

1.10 Codes A, B, & C: Codes A, B, and C are optional user defined codes. Up to three special codes may be ordered as software options. The user must supply a code conversion table for each special code desired.

Table 1. Transmission Code Conversion Chart

HEX CODE	ASCII	BAUDOT (FC)	BAUDOT (LC)	EBCD (LC)	EBCD (UC)	EBCDIC	IPARS	SBT	SELECTRIC (LC)	SELECTRIC (UC)
00	NU	NU	NU	00	00	NU	00	SH	00	00
01	SH	3	E	-	-	SH	1	A	!	01
02	SX	LF	LF	@	z	SX	2	B	t	T
03	EX	-	A	03	03	EX	3	C	03	03
04	ET	SP	SP	8	*	PF	4	D	4	\$
05	EQ	'	S	05	05	HT	5	E	05	05
06	AK	8	I	06	06	LC	6	F	06	06
07	BL	7	U	h	H	DE	7	G	1	?
08	BS	CR	CR	4	:	08	8	H	5	%
09	HT	EQ	D	09	09	RF	9	I	09	09
0A	LF	4	R	0A	0A	SM	0	SX	0A	0A
0B	VT	BL	J	0B	D	VT	*	.	p	P
0C	FF	,	N	0C	0C	FF	▲	<	0C	0C
0D	CR	\$	F	0D	RE	CR	EI	BL	0D	RE
0E	SO	:	C	0E	BY	SO	OE	SB	0E	BY
0F	SI	(K	0F	OF	SI	GH	EB	0F	OF
10	DL	5	T	2	<	DL	NP	&	2	SP
11	D1	+	Z	11	11	D1	/	J	11	11
12	D2)	L	12	12	D2	S	K	12	12
13	D3	2	W	b	B	D3	T	L	=	(
14	D4	#	H	14	14	RE	U	M	14	14
15	NK	6	Y	15	15	NL	V	N	15	15
16	SY	0	P	16	16	BS	W	O	16	16
17	EB	1	Q	17	17	IL	X	P	17	17
18	CN	9	0	18	18	CN	Y	Q	18	18
19	EM	?	B	o	0	EM	Z	R	i	I
1A	SB	&	G	w	W	CC	-	SP	k	K
1B	EC	FS	FS	d	1B	1B	+	\$	1B	1B
1C	FS	.	M	UC	UC	IF	SP	*	UC	UC
1D	GS	/	X	1D	1D	GS	EC	US	1D	1D
1E	RS	=	V	1E	1E	IR	▶	ET	1E	1E
1F	US	LS	LS	LC	LC	US	RG	DL	LC	LC

Table 1. Transmission Code Conversion Chart (Cont'd)

HEX CODE	ASCII	EBCD (LC)	EBCD (UC)	EBCDIC	IPARS	SBT	SELECTRIC (LC)	SELECTRIC (UC)
20	SP	1	=	DS	X	-	1	X
21	!	21	21	SS	J	/	21	21
22	"	22	22	FS	K	S	22	22
23	#	a	A	23	L	T	g	G
24	\$	24	24	BY	M	U	24	24
25	%	r	R	LF	N	V	s	S
26	&	z	Z	EB	O	W	h	H
27	'	27	27	EC	P	X	27	27
28	(28	28	28	O	Y	28	28
29)	n	N	29	R	Z	r	R
2A	*	v	V	SM	:	EC	d	D
2B	+	2B	2B	2B	ER	,	2B	2B
2C	,	2C	RS	2C	TA	%	2C	US
2D	-	2D	2D	EQ	EU	EQ	2D	2D
2E	.	2E	2E	AK	PA	EX	2E	2E
2F	/	2F	HT	BL	CN	HT	2F	HT
30	0	3	+	30	\$	0	30	30
31	1	1	L	31	A	1	v	V
32	2	t	T	SY	B	2	u	U
33	3	33	33	33	C	3	33	33
34	4	#	"	PN	D	4	9	(
35	5	35	35	RS	E	5	35	35
36	6	36	36	UC	F	6	36	36
37	7	.	~	ET	G	7	-	-
38	8	7	>	38	H	8	8	*
39	9	39	39	39	I	9	39	39
3A	:	3A	3A	3A	3A	SY	3A	3A
3B	;	g	G	3B	.	#	,	,
3C	<	3C	3C	D4	BK	@	3C	3C
3D	=	3D	IL	NK	EP	NK	3D	IL
3E	>	3E	EC	3E	S2	M	3E	EC
3F	?	3F	3F	SB	S1	DE	3F	3F

HEX CODE	ASCII	EBCD (LC)	EBCD (UC)	EBCDIC	SELECTRIC (LC)	SELECTRIC (UC)
40	@	SP	40	SP	SP	SP
41	A	41	SP	41	41	41
42	B	42	42	42	42	42
43	C	&	+	43	j	J
44	D	44	44	44	44	44
45	E	q	Q	45	o	O
46	F	y	Y	46	l	L
47	G	47	47	47	47	47
48	H	48	48	48	48	48
49	I	m	M	49	'	"
4A	J	u	U	4A	e	E
4B	K	4B	4B	.	4B	4B
4C	L	4C	PN	<	4C	PN
4D	M	4D	4D	(4D	4D
4E	N	4E	4E	+	4E	4E
4F	O	4F	PF		4F	PF
50	P	50	50	&	50	50
51	Q	k	K	51	.	.
52	R	s	S	52	n	N
53	S	53	53	53	53	53
54	T	0)	54	z	Z
55	U	55	55	55	55	55
56	V	56	56	56	56	56
57	W	57	57	57	57	57
58	X	6	'	58	6	~
59	Y	59	59	59	59	59
5A	Z	5A	5A	!	5A	5A
5B	C	f	F	\$	q	Q
5C	\	5C	5C	*	5C	5C
5D]	5D	BS)	5D	BS
5E	^	5E	EB	;	5E	EB
5F	_	5F	5F	~	5F	5F

APPENDIX C

HEX CODE	ASCII	EBCD (LC)	EBCD (UC)	EBCDIC	SELECTRIC (LC)	SELECTRIC (UC)
60	`	60	60	-	60	60
61	a	j	J	/	m	M
62	b	/	?	62	x	X
63	c	63	63	63	63	63
64	d	9	(64	0)
65	e	65	65	65	65	65
66	f	66	66	66	66	66
67	g	i	I	67	y	Y
68	h	5	%	68	7	&
69	i	69	69	69	69	69
6A	j	6A	6A	:	6A	6A
6B	k	e	E	,	+	:
6C	l	6C	6C	%	6C	6C
6D	m	6D	NL		6D	NL
6E	n	6E	LF	>	6E	LF
6F	o	6F	6F	?	6F	6F
70	p	70	70	70	3	#
71	q	71	71	71	71	71
72	r	72	72	72	72	72
73	s	c	C	73	f	F
74	t	74	74	74	74	74
75	u	\$!	75	w	W
76	v	,	:	76	b	B
77	w	77	77	77	77	77
78	x	78	78	78	78	78
79	y	p	P	\	a	A
7A	z	x	X	:	c	C
7B	{	7B	7B	#	7B	7B
7C		7C	E0	@	7C	ET
7D	}	7D	7D	/	7D	7D
7E	~	7E	7E	=	7E	DE
7F	DE	7F	DL	"	7F	7F

HEX CODE	EBCDIC
80	80
81	a
82	b
83	c
84	d
85	e
86	f
87	g
88	h
89	i
8A	8A
8B	8B
8C	8C
8D	8D
8E	8E
8F	8F
90	90
91	j
92	k
93	l
94	m
95	n
96	o
97	p
98	q
99	r
9A	9A
9B	9B
9C	9C
9D	9D
9E	9E
9F	9F

HEX CODE	EBCDIC
A0	A0
A1	~
A2	s
A3	t
A4	u
A5	v
A6	w
A7	x
A8	y
A9	z
AA	AA
AB	AB
AC	AC
AD	AD
AE	AE
AF	AF
B0	B0
B1	B1
B2	B2
B3	B3
B4	B4
B5	B5
B6	B6
B7	B7
B8	B8
B9	B9
BA	BA
BB	BB
BC	BC
BD	BD
BE	BE
BF	BF

HEX CODE	EBCDIC
C0	{
C1	A
C2	B
C3	C
C4	D
C5	E
C6	F
C7	G
C8	H
C9	I
CA	CA
CB	CB
CC	CC
CD	CD
CE	CE
CF	CF
D0	}
D1	J
D2	K
D3	L
D4	M
D5	N
D6	O
D7	P
D8	Q
D9	R
DA	DA
DB	DB
DC	DC
DD	DD
DE	DE
DF	DF

HEX CODE	EBCDIC
E0	^
E1	E1
E2	S
E3	T
E4	U
D5	V
E6	W
E7	X
E8	Y
E9	Z
EA	EA
EB	EB
EC	EC
ED	ED
EE	EE
EF	EF
F0	0
F1	1
F2	2
F3	3
F4	4
F5	5
F6	6
F7	7
F8	8
F9	9
FA	FA
FB	FB
FC	FC
FD	FD
FE	FE
FF	FF

Table 2. Abbreviations

AK - Acknowledge (ACK)	HT - Horizontal Tabulation
BL - Bell (BEL)	IF - Interchange File Separator (IFS)
BS - Backspace	IG - Interchange Group Separator (IGS)
BP - Bypass (BYP)	IL - Idle
CC - Cursor Control	IR - Interchange Record Separator (IRS)
CN - Cancel (CAN)	IU - Interchange Unit Separator (IUS)
CR - Carriage Return	LC - Lower Case
C1 - Customer Use 1 (CU1)	LF - Line Feed
C2 - Customer Use 2 (CU2)	MM - Start of Manual Message (SMM)
C3 - Customer Use 3 (CU3)	NK - Negative Acknowledgement (NAK)
DE - Delete (DEL)	NL - New Line
DL - Data Link Escape (DLE)	NU - Null (NUL)
DS - Digit Select	PF - Punch Off
D1 - Device Control 1 (DC1)	PN - Punch On
D2 - Device Control 2 (DC2)	RE - Restore (RES)
D3 - Device Control 3 (DC3)	RS - Record Separator
D4 - Device Control 4 (DC4)	SB - Substitute
EB - End of Block (EOB) or End of Transmission Block (ETB)	SH - Start of Heading (SOH)
EC - Escape (ESC)	SI - Shift In
EM - End Medium	SM - Set Mode
EO - Eight Ones	SO - Shift Out
EQ - Enquiry (ENQ)	SP - Space
ET - End of Transmission (EOT)	SS - Start of Significance (SOS)
EX - End of Text (ETX)	SX - Start of Text (STX)
FF - Form Feed	SY - Synchronous Idle (SYN)
FS - File or Field Separator	UC - Upper Case
GS - Group Separator	US - Unit Separator
	VT - Vertical Tabulation